

Overview

- | | | |
|---|--|--|
| <ul style="list-style-type: none"> - Level limit detection in bulk goods/ solids - Compact unit - Very robust and reliable sensors - Wide range of applications, no maintenance - Full-, demand-, empty detector | <ul style="list-style-type: none"> - ATEX, IEC-Ex , FM, CSA, UKEX, TR-CU, INMETRO, KC, CCC - SIL 2 - 1935/2004/EC - 2011/65/EU | <ul style="list-style-type: none"> Gas Ex and Dust Ex approvals Functional safety Food grade material RoHS Conform |
|---|--|--|

Series	RN 3000	RN 6000
	ATEX/ UKEX/ IEC-Ex/ TR-CU/ INMETRO/ KC/ CCC Small housing Sensitivity >15 g/l (0.9 lb/ft³)	ATEX/ UKEX/ IEC-Ex/ FM/ CSA/ TR-CU/ INMETRO/ KC/ CCC SIL 2 Spacious housing Sensitivity >15 g/l (0.9 lb/ft³)

Housing



RN ..001
 Short extension length

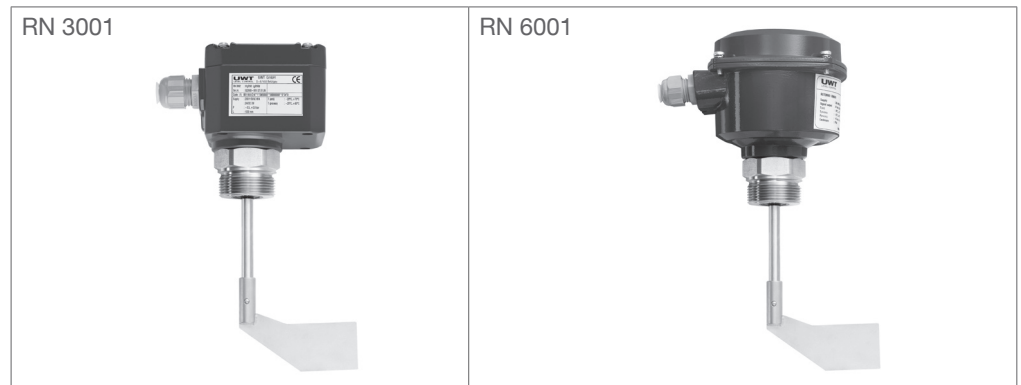

RN ..002
 Pipe extension vertical



Overview

RN ..002-rope
 Rope extension



RN ..003
 Angled extension

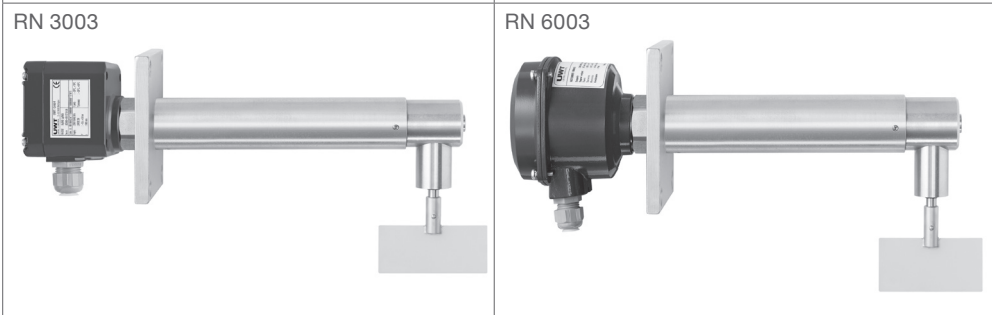

RN ..004
 Pipe extension
 horizontal

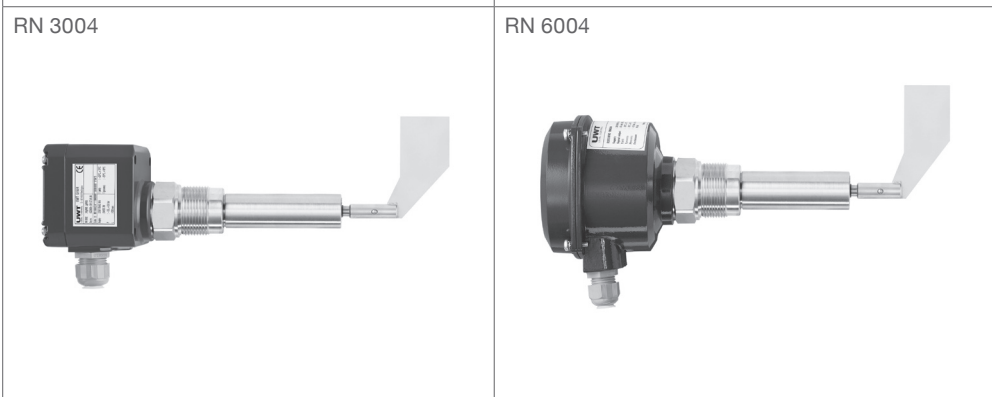

RN 3005
 Extra short version
 for use in
 loading bellow



Specifications

Series		RN 3000	RN 6000	
Approvals	CE/ UKCA/ TR-CU	•	•	
	ATEX/ UKEX/ IEC-Ex/ INMETRO/ TR-CU/ KC/ CCC:			
	Zone 20/21	Dust Ignition Proof	•	•
	Zone 1	Flameproof/ Increased Safety		•
	FM/ CSA:			
	Ordinary Locations			•
	Cl. II, III Div. 1	Dust Ignition Proof		•
	Cl. I Div. 1	Explosionproof		•
	Zone 1	Flameproof/ Increased Safety		•
Functional safety	SIL 2 (IEC 61508)		•	

Technical data	Ambient temperature	-20°C .. +70°C (-4°F .. +158°F) -20°C .. +60°C (-4°F .. +140°F) EX -40°C (-40°F) with heating	-20°C .. +50°C (-4°F .. +122°F) -40°C (-40°F) with heating
	Type of protection	IP66 ⁽⁵⁾ and NEMA Type 4/4X (RN6000)	
	Material housing	Aluminium or plastics PA6 (RN3000, optional)	
	Process connection/ extension material	Aluminium or 1.4301 (304)/ 1.4305 (303)/ 1.4541 (321) or 1.4404 (316L)	
	Material of measuring vane and shaft	1.4301 (SS 304)/ 1.4305 (303) or 1.4404 (316L)	

Cable entries (by default)

Depending on model selected, the following cable entries are supported:

Version:	Cable entries:
Flameproof (pos.2 T,D,L,5)	M20 x 1.5 (1x open conduit + 1x blind plug)
FM and CSA (pos.2 M,N,S,U)	NPT ½" tapered ANSI B1.20.1 (1x open conduit + 1x blind plug)
All other versions	M20 x 1.5 (1x screwed cable gland + 1x blind plug)

Specifications

Electronics	RN 3000							
	Power supply		Output signal					
			SPDT ⁽¹⁾	DPDT	PNP	FSH/ FSL ⁽²⁾	Adjustable delay	Fail safe alarm
	AC version	24 V or 48 V or 115 V or 230 V AC	•	-	-	-	-	-
	DC version	24 V DC	•	-	-	-	-	-
	DC version	24 V DC PNP	-	-	•	•	•	-
	Universal voltage	24 V DC/ 22 .. 230 V AC	•	-	-	•	•	option
	RN 6000							
	Power supply		Output signal					
			SPST	SPDT ⁽¹⁾	DPDT	PNP	FSH/ FSL ⁽²⁾	Adjustable delay
	AC version	24 V or 48 V or 115 V or 230 V AC	-	•	-	-	-	-
	DC version	24 V DC	-	•	-	-	-	-
Universal voltage	24 V DC/ 22 .. 230 V AC	-	-	• ⁽³⁾	-	•	•	option
Universal voltage SIL 2	24 V DC/ 22 .. 230 V AC	•	• ⁽⁴⁾	-	-	•	•	-

⁽¹⁾ Micro switch, with Universal voltage Relais

⁽²⁾ Switchable signal output (Fail safe high/ low)

⁽³⁾ For Ex approval "Increased safety" (pos.2 R,C,S,K,4) not in combination with option Fail safe alarm

⁽⁴⁾ Additional output, without SIL

⁽⁵⁾ For version with plug the type of protection can be lower (see pos.35)

Specifications

Extensions	RN .001	Process temperature	-40/ -25 .. +80/ 150/ 250/ 350/ 600/ 1,100°C (-40/ -13 .. +176/ 302/ 482/ 662/ 1,112/ 2,012°F)
		Process pressure	-0.9 .. +0.8bar; -0.9 .. +5/ 10 bar (-13.1 .. +11.6; -13.1 .. +72.5/ 145 psi)
		Length of extension	
		Full detector vertical from the top	70 .. 1,000 mm (2.76 .. 39.4")
		Full detector with pendulum shaft, vertical from the top	300 .. 1,000 mm (11.8 .. 39.4")
		Full detector oblique from the top	70 .. 300 mm (2.76 .. 11.8")
		Full detector horizontal	70 .. 300 mm (2.76 .. 11.8")
		Demand or empty detector horizontal	70 .. 150 mm (2.76 .. 5.9") *
		Empty detector oblique from the bottom	70 .. 150 mm (2.76 .. 5.9") *
	RN .002	Process temperature	-40/ -25 .. +80/ 150/ 250/ 350/ 600/ 1,100°C (-40/ -13 .. +176/ 302/ 482/ 662/ 1,112/ 2,012°F)
		Process pressure	-0.9 .. +0.8 bar; -0.9 .. +5/ 10 bar (-13.1 .. +11.6; -13.1 .. +72.5/ 145 psi)
		Length of extension	
		Full detector vertical from the top	250 .. 3,000 mm (9.84 .. 118")/ 4,000 mm (158") with support of the extension pipe
	Full detector oblique from the top	250 .. 3,000 mm (9.84 .. 118") with option "Bearing at tube end"	
	RN..002-rope	Process temperature	-40/ -25 .. +80/ 150/ 250/ 350/ 600°C (-40/ -13 .. +176/ 302/ 482/ 662/ 1,112°F)
		Process pressure	-0.9 .. +0.8 bar; -0.9 .. +5/ 10 bar (-13.1 .. +11.6; -13.1 .. +72.5/ 145 psi)
		Length of extension	
		Full detector vertical from the top	500 .. 10,000 mm (19.7 .. 394") (observe max. traction)
	RN .003	Process temperature	-40/ -25 .. +80/ 150/ 250°C (-40/ -13 .. +176/ 302/ 482°F)
		Process pressure	-0.9 .. +0.8 bar; -0.9 .. +5/ 10 bar (-13.1 .. +11.6; -13.1 .. +72.5/ 145 psi)
		Length of extension	
		Demand or empty detector horizontal	125 .. 600 mm (4.92 .. 23.6")
		Empty detector oblique from the bottom	125 .. 600 mm (4.92 .. 23.6")
	RN .004	Process temperature	-40/ -25 .. +80/ 150/ 250/ 350/ 600°C (-40/ -13 .. +176/ 302/ 482/ 662/ 1,112°F)
Process pressure		-0.9 .. +0.8 bar; -0.9 .. +5/ 10 bar (-13.1 .. +11.6; -13.1 .. +72.5/ 145 psi)	
Length of extension			
Full detector vertical from the top		150 .. 600 mm (5.90 .. 23.6")	
Full detector oblique from the top		150 .. 300 mm (5.90 .. 11.8")	
Full detector horizontal		150 .. 300 mm (5.90 .. 11.8")	
Demand or empty detector horizontal		150 .. 300 mm (5.90 .. 11.8") *	
Empty detector oblique from the bottom		150 .. 300 mm (5.90 .. 11.8") *	
RN 3005	Process temperature	-40/ -25 .. +80°C (-40/ -13 .. +176°F)	
	Process pressure	-0.9 .. +0.8 bar (-13.1 .. +11.6 psi)	
	Length of extension		
	Application "Loading bellow"	90 mm (3.5")	

* A protective canopy is recommended for applications with high mechanical loads

Applications

RN ..001
Short extension length

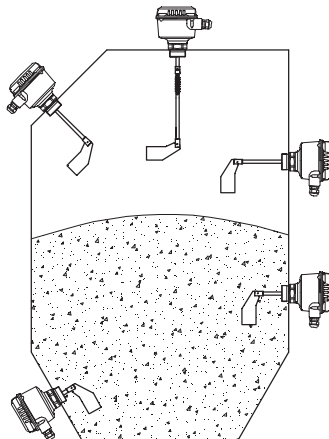

RN ..002
Pipe extension vertical

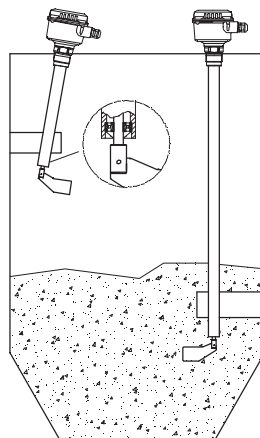

Deviation up to max. 10° from vertical installation only with option „bearing at tube end" possible.

RN ..002 - rope
Rope extension

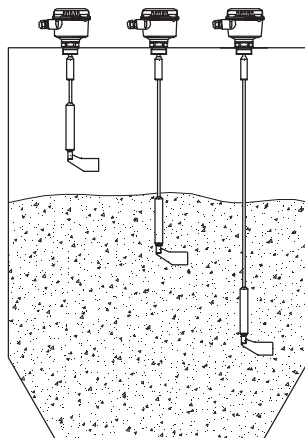

Details see external documentation „Technical information / Instruction manual"

Applications

RN ..003
Angled extension

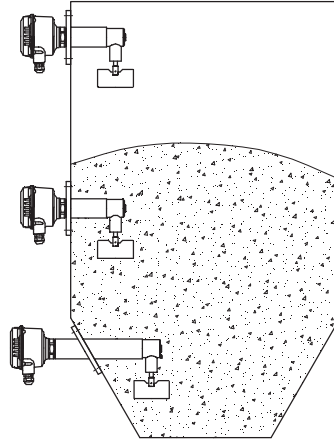

RN ..004
Pipe extension horizontal

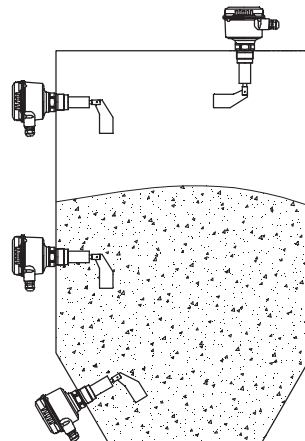

RN 3005
Extra short version

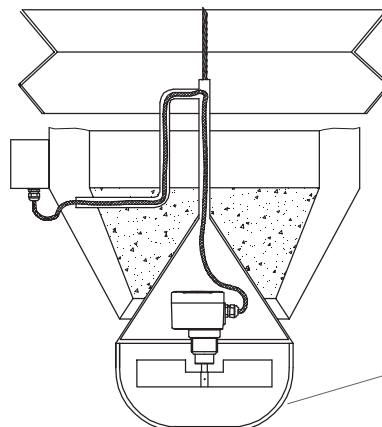

Application
„Loading bellow“

mechanical
protection for
sensor

Details see external documentation „Technical information / Instruction manual“

Options

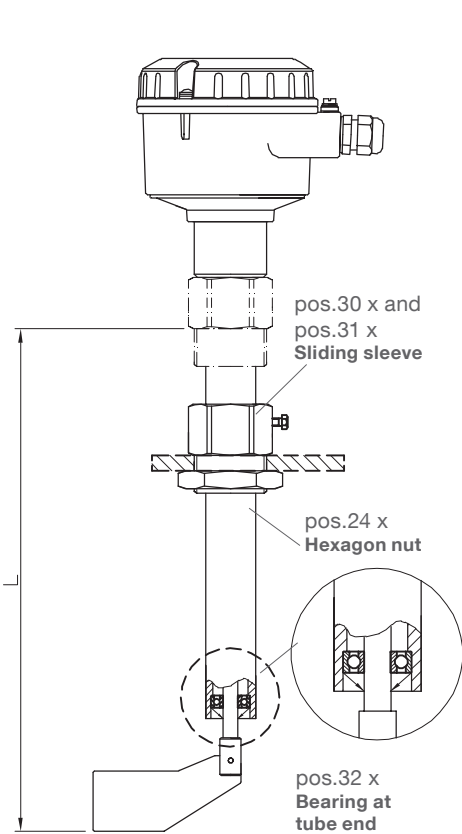

pos.36
 Kit "pendulum shaft"

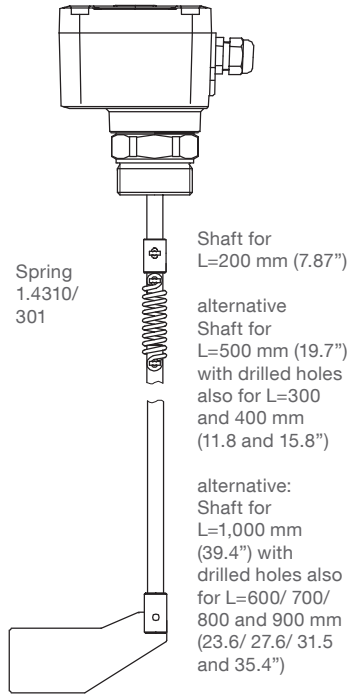

pos.39
 Kit „rope extension"

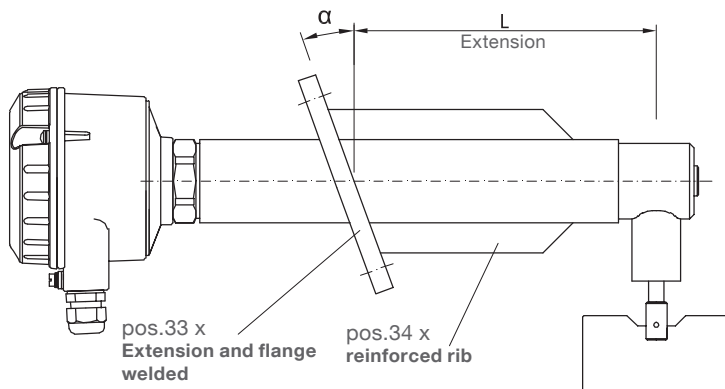
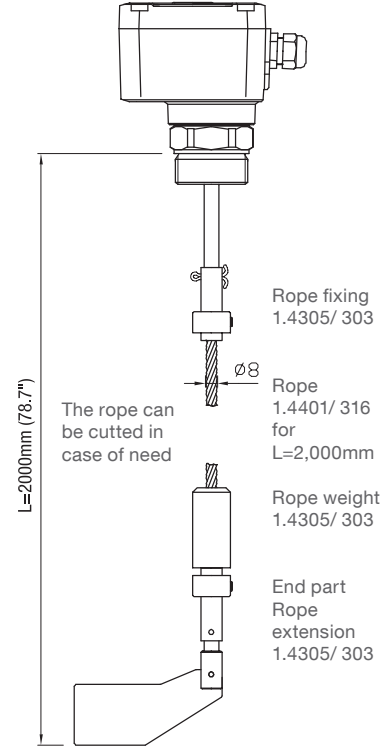

Signal lamp

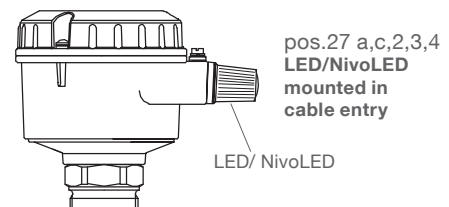

Connection of the wires to the internal terminals of the unit refer to documentation "Plugs and Signal lamps - Connecting diagram".

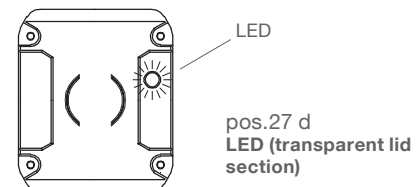
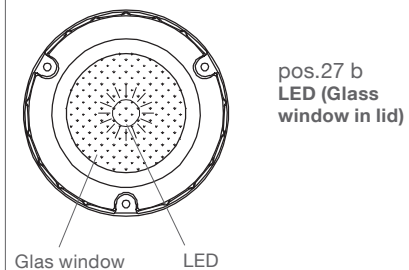

Options

pos.29
 EHEDG approval
 (ED class I)

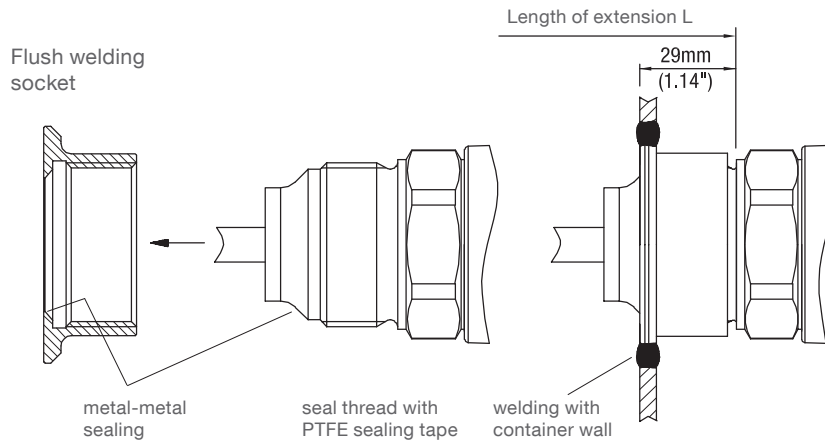

Plug

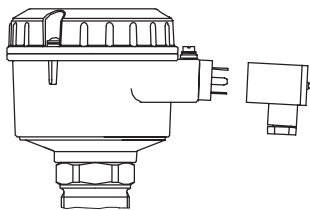

pos.35 x
Valve connector
 max. 230 V
 Enclosure plastic
 Protection IP65
 $-40\text{ °C} \leq T_a \leq +125\text{ °C}$

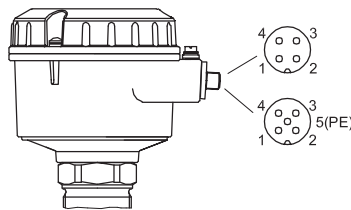

pos.35 a,b
Plug M12
 max. 25 V (4-pole), 60 V (5-pole)
 Enclosure brass
 Protection IP66
 $-25\text{ °C} \leq T_a \leq +80\text{ °C}$

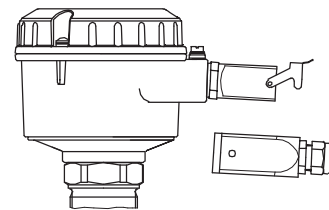

pos.35 c
Plug Han 4A
 max. 230 V
 Enclosure zinc
 Protection IP65
 $-40\text{ °C} \leq T_a \leq +125\text{ °C}$

Connection of the plug wires to the internal terminals of the unit refer to documentation "Plugs and Signal lamps - Connecting diagram".

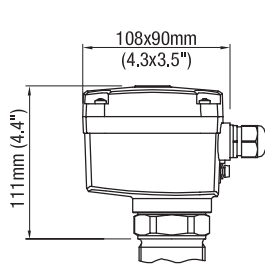

pos.16 a
Material of housing
 Plastics PA6

pos.21 x
Weather protection cover

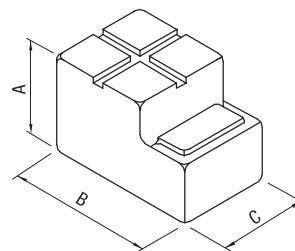

	RN 3000	RN 6000
A	100 mm (3.9")	130 mm (5.1")
B	165 mm (6.5")	200 mm (7.9")
C	95 mm (3.7")	125 mm (4.9")

pos.15
Flat gasket

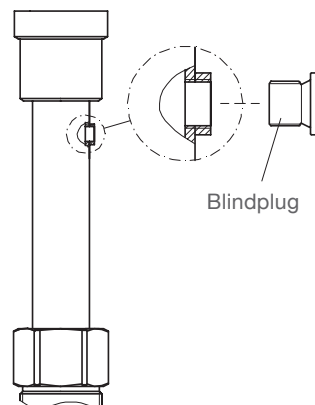
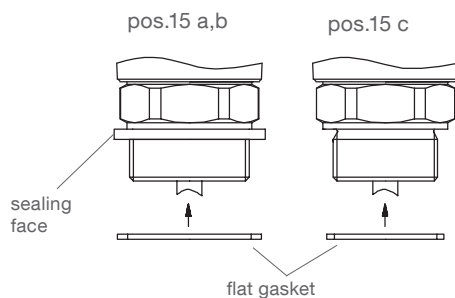

pos.19
Compressed air connection

pos.19 a: G1/4"
 pos.19 b: G1/8"

Dimensions

Housing versions

Series RN 3000
Standard

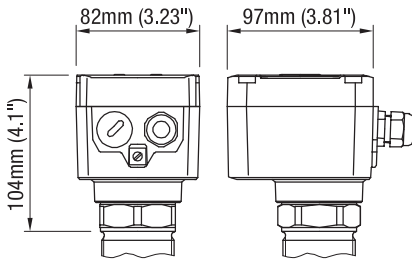

Series RN 6000
Standard

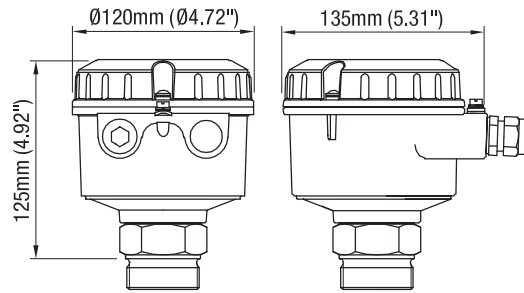

Series RN 6000
de explosionproof with increased
safety terminal box

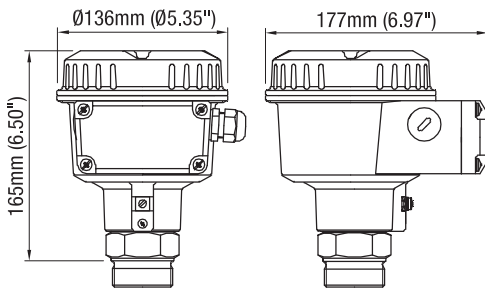

Series RN 6000
d flameproof/ explosionproof

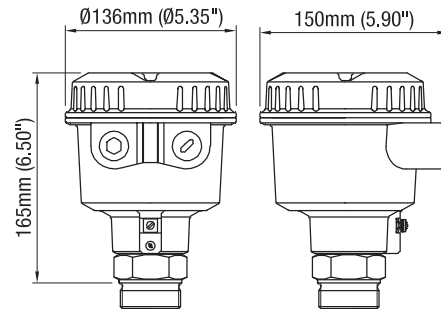

Extensions

RN ..001

Process temperature	A
150°C (302°F)	200mm (7.87")
250°C (482°F)	200mm (7.87")
350°C (662°F)	300mm (11.8")
600°C (1112°F)	400mm (15.7")
1.100°C (2012°F)	700mm (27.6")

Thread/ flange

Temperature extended shaft

Triclamp

EHEDG ED class I

With measuring vanes "boot shaped" and "hinged vane" the length "L" can be increased by 10mm (0.39"). Details see selection code pos.10.

Dimensions

RN ..002

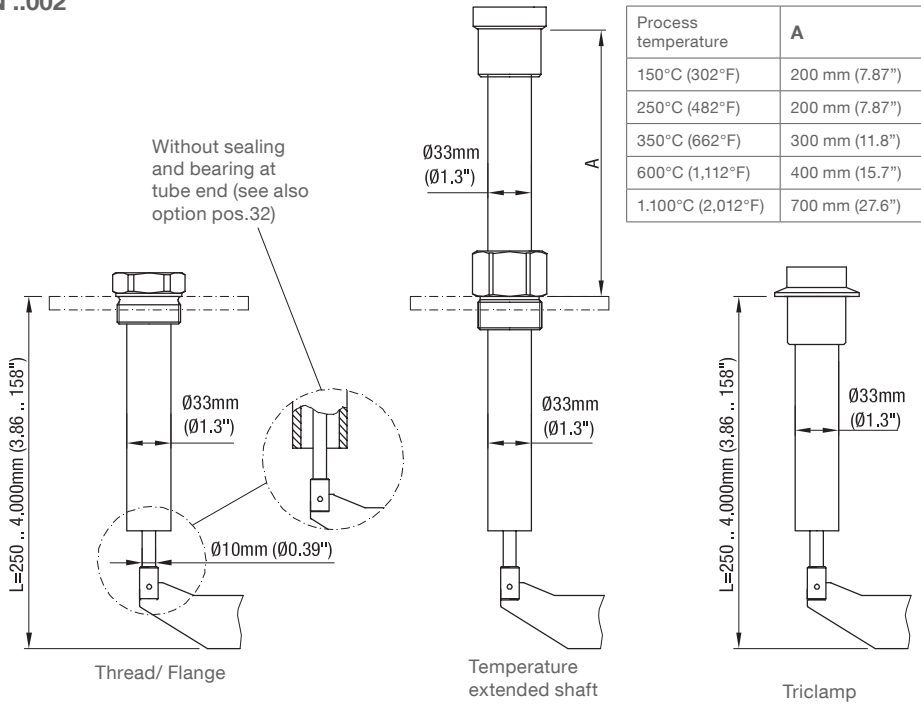

With measuring vanes "boot shaped" and "hinged vane" the length "L" can be increased by 10mm (0.39"). Details see selection code pos.10.

RN ..002 rope

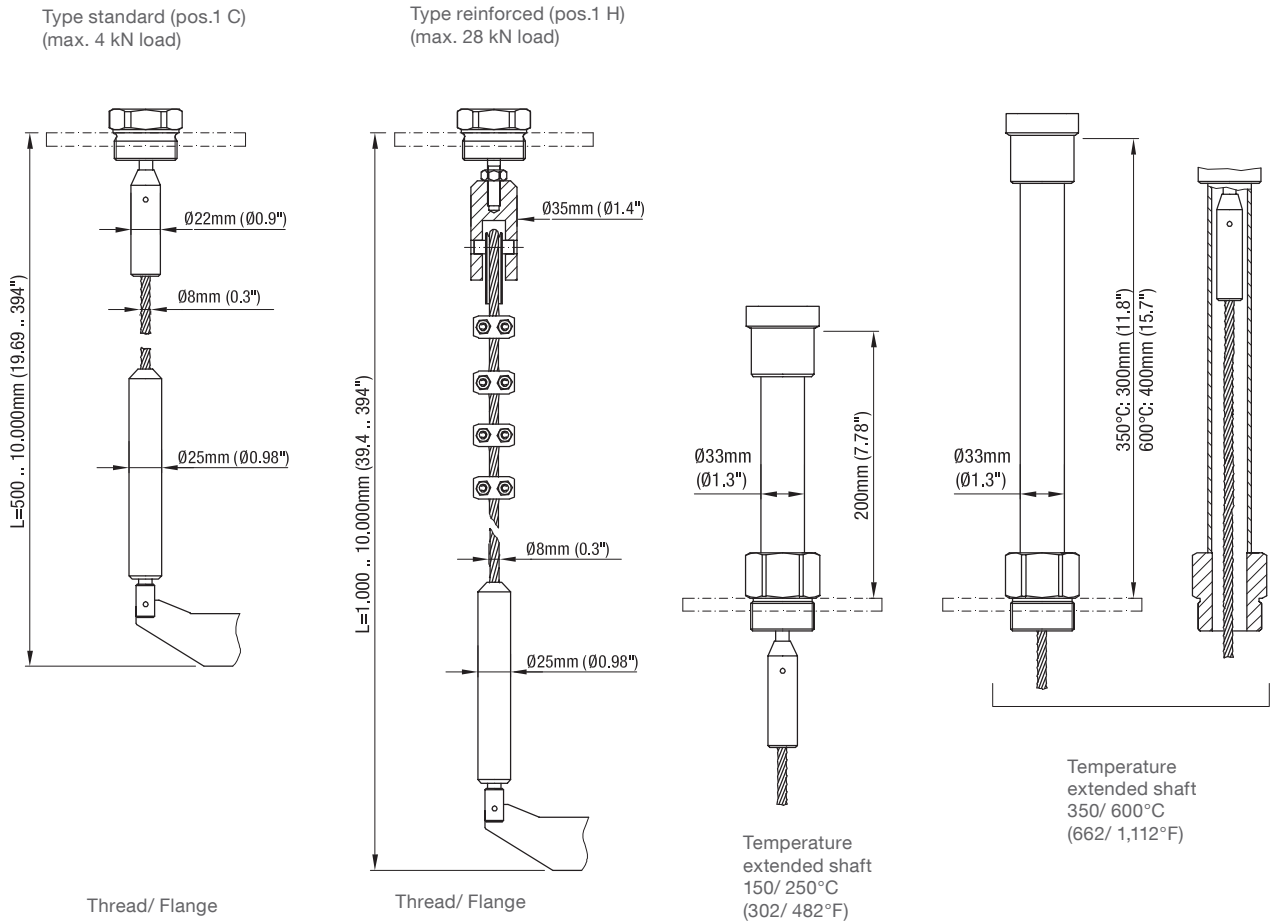

With measuring vanes "boot shaped" and "hinged vane" the length "L" can be increased by 10mm (0.39"). Details see selection code pos.10.

Dimensions

RN ..003

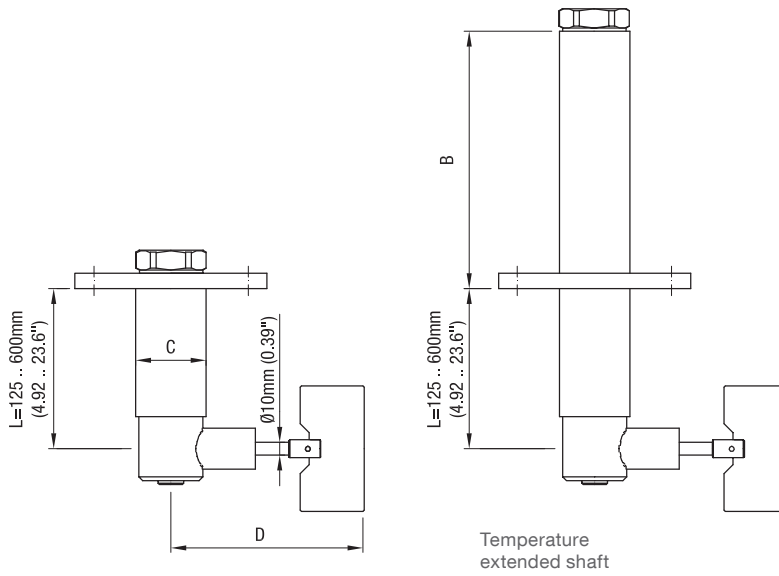

Process temperature	B
80°C (176°F) 0.8 bar (11.6 psi)	10 mm (0.39")
80°C (176°F) 5/ 10 bar (73/ 145 psi)	75 mm (2.95")
150/ 250°C (302/ 482°F) 0.8/ 5/10 bar (11.6/ 73/ 145 psi)	210 mm (8.27")

Material	C
steel	ø55 mm (ø2.17")
aluminium	ø60 mm (ø2.36")

Vane	D
50 mm x .. mm (1.97" x ..")	139 mm (5.47")
98 mm x .. mm (3.86" x ..")	187 mm (7.36")

RN ..004

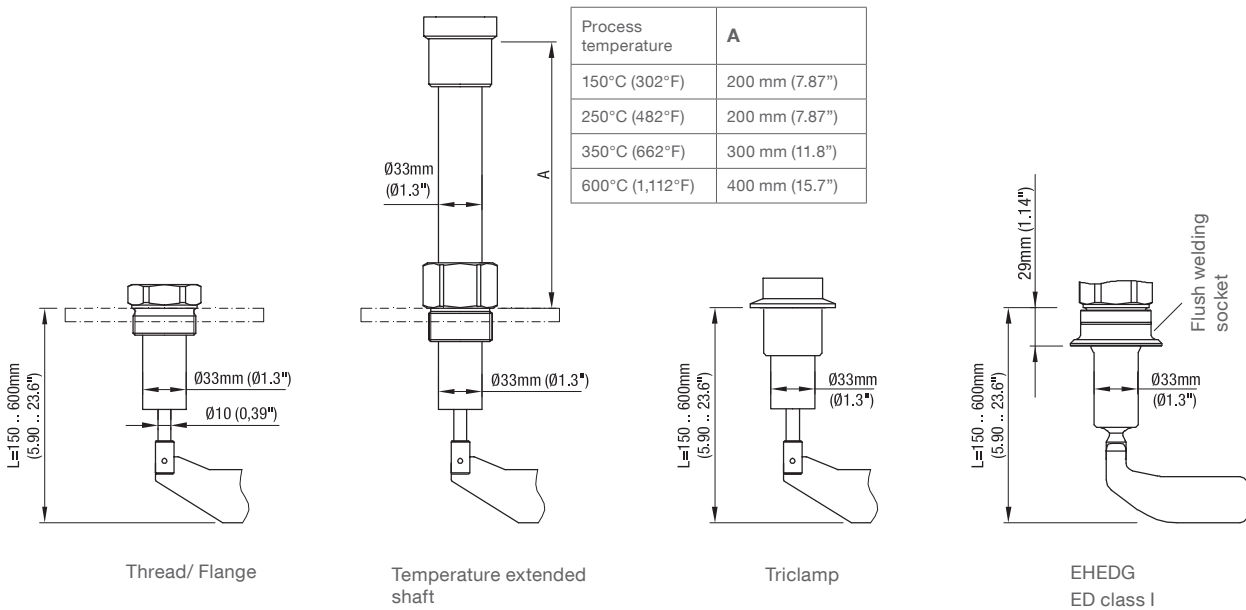

With measuring vanes "boot shaped" and "hinged vane" the length "L" can be increased by 10mm (0.39"). Details see selection code pos.10.

RN 3005

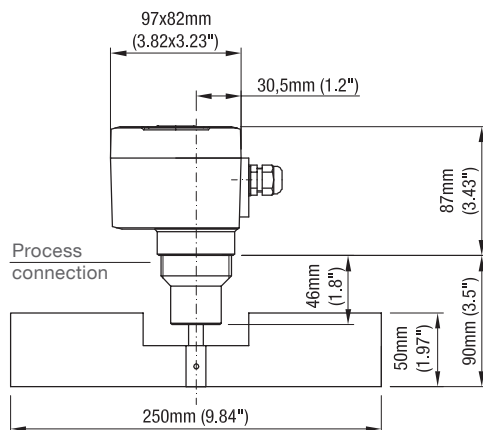

Dimensions

Measuring vanes

code	type	a	b
B	rectangular	50 mm (1.97")	98 mm (3.86")
C	rectangular	50 mm (1.97")	150 mm (5.90")
E	rectangular	50 mm (1.97")	250 mm (9.84")
F	rectangular	98 mm (3.86")	98 mm (3.86")
G	rectangular	98 mm (3.86")	150 mm (5.90")
I	rectangular	98 mm (3.86")	250 mm (9.84")

code B,C,E,F,G,I
 rectangular vane

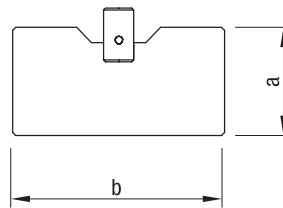

code P
 notched 40 x 80

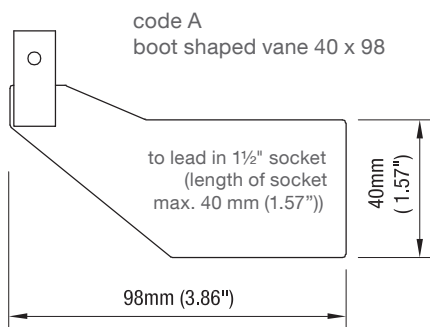
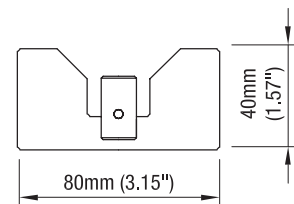

code K
 hinged vane 98 x 200 double
 sided

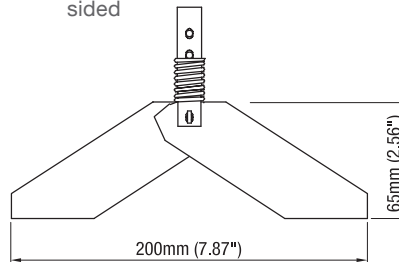

b=37 mm (1.46")
 for 1½" / 1¼"
 b=28 mm (1.1")
 for 1" / M32 x 1.5

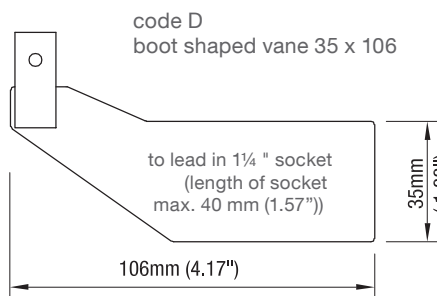

code S
 hinged vane 98 x 100
 single sided

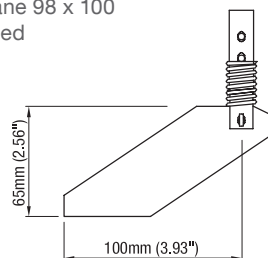

b=37 mm (1.46")
 für 1½" / 1¼"
 b=28mm (1.1")
 for 1" / M32 x 1.5

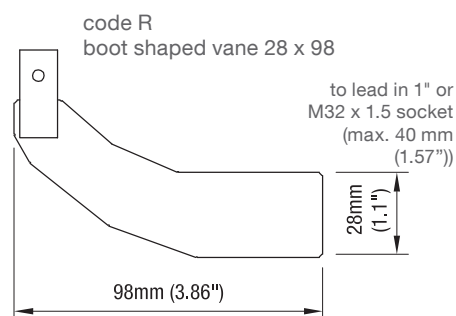

Insertion of the hinged vane
 through a long socket

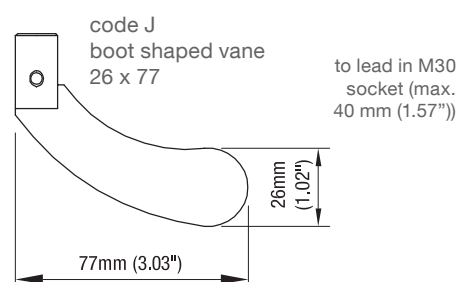
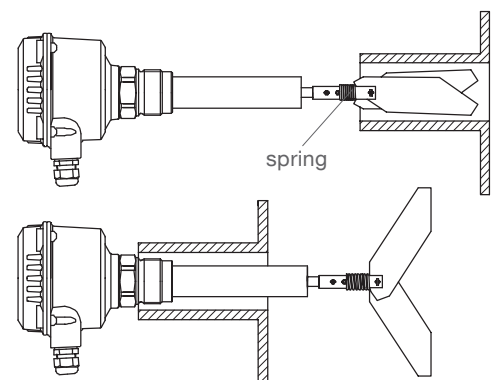

code M
 rubber vane 98 x 250

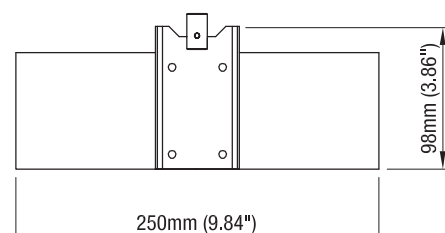

Dimensions

Sensitivity

The table shows approximate values for the minimum densities, at which a normal function should be possible.

Vane	*Minimum density in g/l = kg/m ³ (lb/ft ³) (without guarantee)			
	Vane completely covered with bulk material		Bulk material is 100 mm (3.93") above covered vane	
	Spring adjustment		Spring adjustment	
	fine	medium (factory setting)	fine	medium (factory setting)
Boot shaped vane 40 x 98	200 (12)	300 (18)	100 (6)	150 (9)
Boot shaped vane 35 x 106	200 (12)	300 (18)	100 (6)	150 (9)
Boot shaped vane 28 x 98	300 (18)	500 (30)	150 (9)	200 (12)
Boot shaped 26 x 77	350 (21)	560 (33)	200 (12)	250 (15)
Vane 50 x 98	300 (18)	500 (30)	150 (9)	250 (15)
Vane 50 x 150	80 (4,8)	120 (7.2)	40 (2.4)	60 (3.6)
Vane 50 x 250	30 (1.8)	50 (3)	15 (0,9)	25 (1.5)
Vane 98 x 98	100 (6)	150 (9)	50 (3)	75 (4.5)
Vane 98 x 150	30 (1.8)	50 (3)	15 (0,9)	25 (15)
Vane 98 x 250	20 (1.2)	30 (1.8)	15 (0,9)	15 (0.9)
Hinged vane 98 x 200 b=37 double sided	70 (4.2)	100 (6)	35 (2.16)	50 (3)
Hinged vane 98 x 200 b=28 double sided	100 (6)	150 (9)	50 (3)	75 (4.5)
Hinged vane 98 x 100 b=37 single sided	200 (12)	300 (18)	100 (6)	150 (9)
Hinged vane 98 x 100 b=28 single sided	300 (18)	500 (30)	150 (9)	250 (15)

The above mentioned data is a guideline and is for loose, non compacted material.

During the filling the bulk density can change (e. g. for fluidised material).

* For versions for high temperatures pos.3 6 (> 600°C (1,112°F)) and/ or with option 26 (heating of housing) the above mentioned data must be multiplied by 1.5.

Dimensions / Detailed Ex-markings

Flanges

Code	Type	Number of holes	d2	Lk	D	T (thickness)
H	flange 150x150	4	18 mm (0.71")	170 mm (6.69")	150 mm (5.90")	10 mm (0.39")
I	flange 150x150	4	14 mm (0.55")	170 mm (6.69")	150 mm (5.90")	10 mm (0.39")
K	flange DN32 PN6	4	14 mm (0.55")	90 mm (3.54")	120 mm (4.72")	14 mm (0.55")
N	flange DN50 PN16	4	18 mm (0.71")	125 mm (4.92")	165 mm (6.50")	18 mm (0.71")
L	flange DN100 PN6	4	18 mm (0.71")	170 mm (6.69")	210 mm (8.27")	16 mm (0.63")
M	flange DN100 PN16	8	18 mm (0.71")	180 mm (7.09")	220 mm (8.66")	20 mm (0.79")
S	flange 2" 150lbs	4	19.1 mm (0.75")	120.7 mm (4.75")	152.4 mm (6.01")	19.1 mm (0.75")
T	flange 3" 150lbs	4	19.1 mm (0.75")	152.4 mm (6.01")	190.5 mm (7.5")	23.9 mm (0.94")
U	flange 4" 150lbs	8	19.1 mm (0.75")	190.5 mm (7.5")	228.6 mm (9.0")	23.9 mm (0.94")

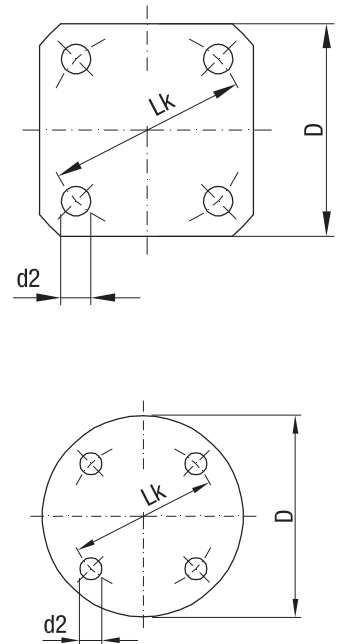

Detailed Ex-markings

Code	Certificate	Housing
pos.2 0	CE/ UKCA/ TR-CU	Standard
pos.2 W	ATEX II 1/2D Ex ta/tb IIIC T! Da/Db	Standard
pos.2 R	ATEX II 2G Ex db eb IIC T! Gb and ATEX II 1/2D Ex ta/tb IIIC T! Da/Db	de
pos.2 T	ATEX II 2G Ex db IIC T! Gb and ATEX II 1/2D Ex ta/tb IIIC T! Da/Db	d
pos.2 A	IEC-Ex ta/tb IIIC T! Da/Db	Standard
pos.2 C	IEC-Ex db eb IIC T! Gb and IEC-Ex ta/tb IIIC T! Da/Db	de
pos.2 D	IEC-Ex db IIC T! Gb and IEC-Ex ta/tb IIIC T! Da/Db	d
pos.2 M	FM/ CSA general purpose	Standard
pos.2 N	FM/ CSA DIP Cl. II, III Div. 1 Gr. E,F,G CSA Ex DIP A20/21	Standard
pos.2 S	FM Cl. I Zone 1 AEx de IIC and FM/ CSA DIP Cl. II,III Div. 1 Gr. E,F,G CSA Cl. I Zone 1 Ex de IIC and CSA Ex DIP A20/21	de
pos.2 U	FM XP Cl. I,II,III Div. 1 Gr. B-G and FM Cl. I Zone 1 AEx d IIC CSA XP Cl. I,II,III Div. 1 Gr. B-G CSA Cl. I Zone 1 Ex d IIC and CSA Ex DIP A20/21	d
pos.2 E	TR-CU Ex ta/tb IIIC T90°C...T250°C Da/Db X	Standard
pos.2 K	TR-CU 1Ex d e IIC T5...T2 Gb X Ex ta/tb IIIC T90°C...T250°C Da/Db X	de
pos.2 L	TR-CU 1Ex d IIC T5...T2 Gb X Ex ta/tb IIIC T90°C...T250°C Da/Db X	d
pos.2 2	+pos.20 a INMETRO Ex ta/tb IIIC T250°C...T90°C Da/Db IP6X	Standard
pos.2 4	+pos.20 a INMETRO Ex db eb IIC T5...T2 Gb IP66 Ex ta/tb IIIC T250°C...T90°C Da/Db IP6X	de
pos.2 5	+pos.20 a INMETRO Ex db IIC T5...T2 Gb IP66 Ex ta/tb IIIC T250°C...T90°C Da/Db IP6X	d
pos.2 2	+pos.20 b KC Ex t IIIC T!	Standard
pos.2 5	+pos.20 b KC Ex d IIC T! Ex t IIIC T!	d
pos.2 2	+pos.20 c CCC Ex ta/tb IIIC T! Da/Db	Standard
pos.2 5	+pos.20 c CCC Ex db IIC T! Gb Ex ta/tb IIIC T! Da/Db	d
pos.2 2	+pos.20 e UKEX II 1/2D Ex ta/tb IIIC T! Da/Db	Standard
pos.2 4	+pos.20 e UKEX II 2G Ex db eb IIC T! Gb and UKEX II 1/2D Ex ta/tb IIIC T! Da/Db	de
pos.2 5	+pos.20 e UKEX II 2G Ex db IIC T! Gb and UKEX II 1/2D Ex ta/tb IIIC T! Da/Db	d

Electrical installation Series RN 3000

Version:

- AC
- DC
- **Universal voltage**

Power supply:

- **AC version:**
 24 V or 48 V or 115 V or 230 V 50/60 Hz max. 4 VA
 All voltages $\pm 10\%$ ⁽¹⁾
 Supply voltage as selected.
 External fuse: max. 10 A, fast or slow, HBC, 250 V
- **DC version:**
 24 V DC $\pm 15\%$ ⁽¹⁾ max. 2.5 W
 External fuse: not required
- **Universal voltage:**
 24 V DC $\pm 15\%$ ⁽¹⁾ max. 4 W
 22 .. 230 V 50/60 Hz $\pm 10\%$ ⁽¹⁾ max. 10 VA
 External fuse: not required

⁽¹⁾ including $\pm 10\%$ of EN 61010

Signal and alarm output:

Micro switch or relay, SPDT contact
 max. 250 V AC, 2 A, 500 VA ($\cos\phi = 1$)
 max. 250 V DC, 2 A, 60 W
 External fuse: max. 10 A, fast or slow, HBC, 250 V

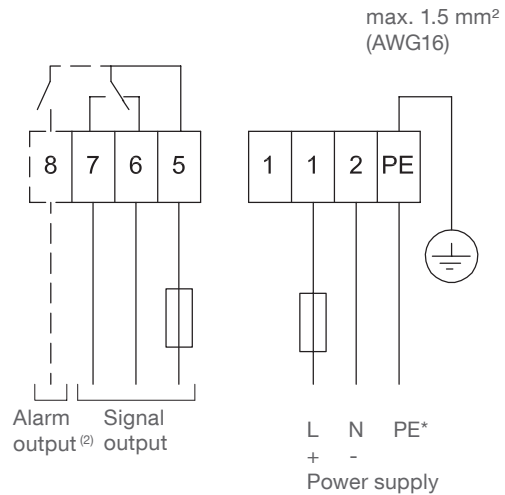

⁽²⁾ With option Fail safe alarm (rotation control)
 Contact open when de-energised

Version:

- PNP

Power supply:

24 V DC $\pm 15\%$ ⁽¹⁾
⁽¹⁾ including $\pm 10\%$ of EN 61010
 Input current: max. 0.6 A

Signal output:

Load max. 0.4 A
 Output voltage equal to input voltage, drop <2.5 V
 Open collector
 Protected against short circuit and overload

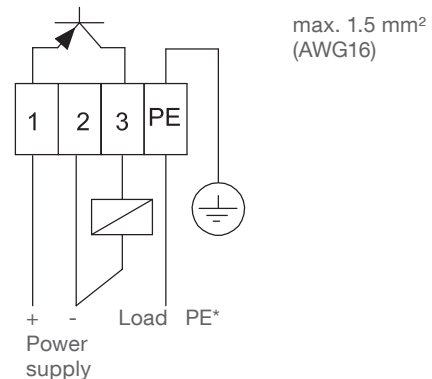

* Protection against static charge:

The PE terminal of the unit must be grounded to avoid static charging of the unit.
 This is particularly important for applications with pneumatic conveying.

Electrical installation Series RN 6000

Version:

- AC
- DC

Power supply:

- **AC version:**
 24 V or 48 V or 115 V or 230 V 50/ 60 Hz max. 4 VA
 All voltages $\pm 10\%$ ⁽¹⁾
 Supply voltage as selected.
 External fuse: max. 10 A, fast or slow, HBC, 250 V

- **DC version:**
 24 V DC $\pm 15\%$ ⁽¹⁾ max. 2.5 W
 External fuse: not required

⁽¹⁾ including $\pm 10\%$ of EN 61010

Signal output:

Micro switch, SPDT contact
 max. 250 V AC, 5 A, non inductive
 max. 30 V DC, 4 A, non inductive
 External fuse: max. 10 A, fast or slow, HBC, 250 V

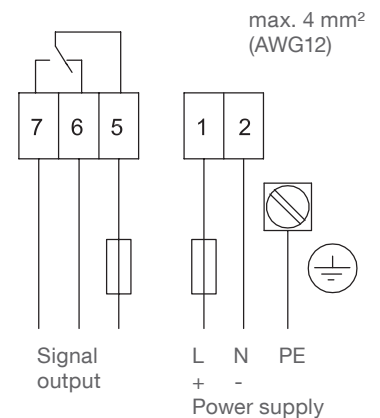

Version:

- Universal voltage
 (ohne SIL 2)

Power supply:

24 V DC $\pm 15\%$ ⁽¹⁾ max. 4 W
 22 .. 230 V 50/ 60 Hz $\pm 10\%$ ⁽¹⁾ max. 10 VA

⁽¹⁾ including $\pm 10\%$ of EN 61010

Signal and alarm output:

Relay DPDT contact
 max. 250 V AC, 5 A, non inductive;
 max. 30 V DC, 4 A, non inductive
 External fuse: max. 10 A, fast or slow, HBC, 250 V

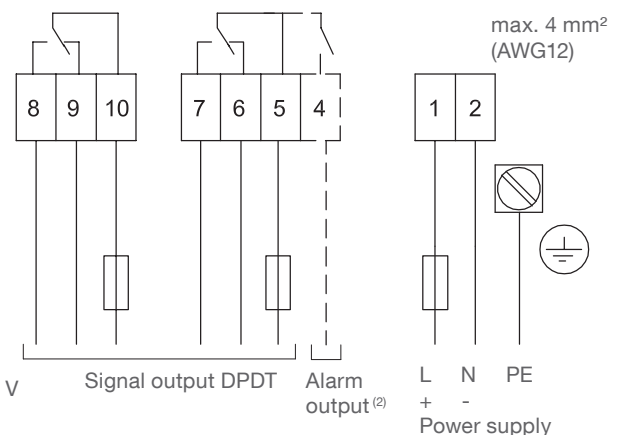

⁽²⁾ With option Fail safe alarm (rotation control)
 Contact open when de-energised

Version:

- Universal voltage
 SIL 2

Power supply:

24 V DC $\pm 15\%$ ⁽¹⁾ max. 4 W
 22 .. 230 V 50/ 60 Hz $\pm 10\%$ ⁽¹⁾ max. 10 VA

⁽¹⁾ including $\pm 10\%$ of EN 61010

Signal output:

Relay SPST/ SPDT
 max. 250 V AC, 5 A, non inductive;
 max. 30 V DC, 4 A, non inductive
 External fuse:
 max. 10 A, fast or slow, HBC, 250 V

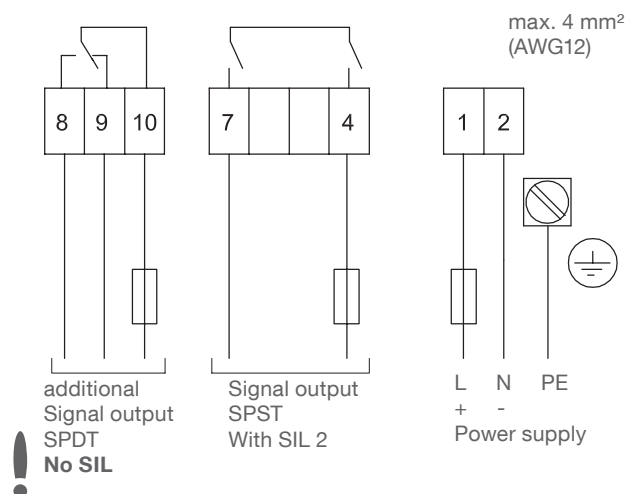

* Protection against static charge:

- The PE terminal of the unit must be grounded to avoid static charging of the unit.
- This is particularly important for applications with pneumatic conveying.