

# UWWT

LEVEL. UP TO THE MAX.



**6** YEARS  
GUARANTEE  
APPROVED  
QUALITY

**SOLUTIONS FOR THE  
SYNTHETICS INDUSTRY**



**SUCCESSFUL**

**=**

**TOGETHER**

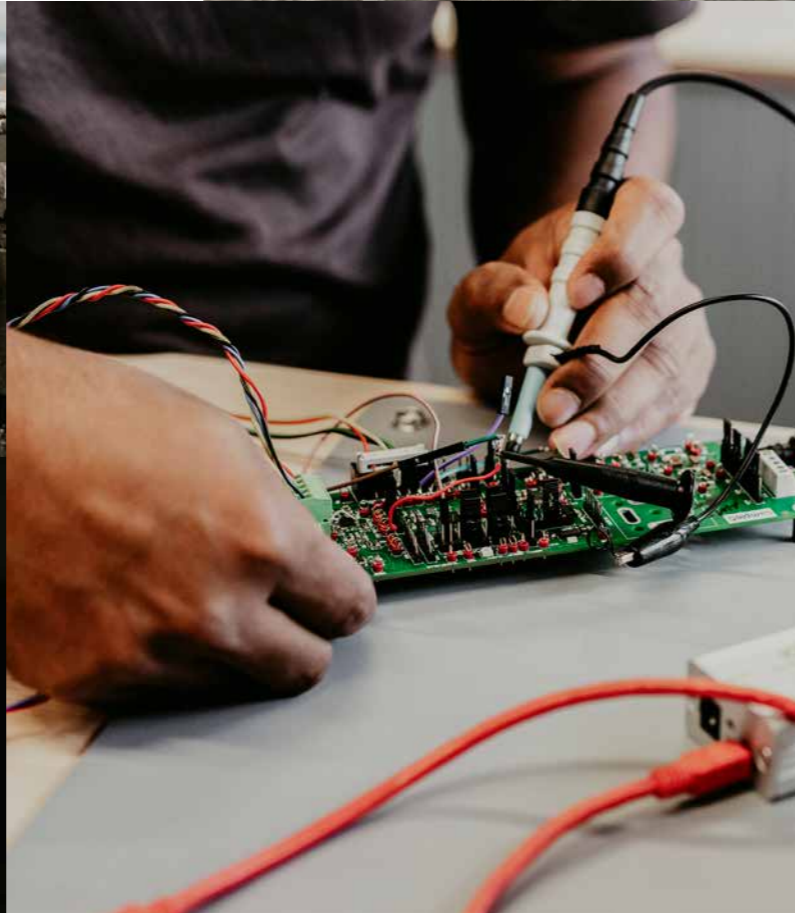

### LEVEL. UP TO THE MAX.

As an owner-managed, medium-sized company, with an international sales network in over 90 countries and personal contacts available locally, UWT stands for a sustainable partnership at eye level - globally and regionally.

The core competence of UWT lies in level, point, and interface measurement. We measure bulk solids, from the finest powder to coarse, abrasive materials, as well as all types of liquids, including high-viscosity pastes and foams.

In the field of point level measurement for bulk materials, UWT has achieved a special position and set new standards with the rotary paddle switch.

### INNOVATIVE SOLUTIONS AND DIGITALISATION

Modern, high-quality technologies ensure a continuous process flow. UWT sensors are designed with maximum process compatibility, allowing seamless integration into systems and providing optimal support. Additionally, comprehensive digitalisation is offered: cutting-edge eTools enable easy product selection, configuration, and commissioning. Intuitive operation and innovative device communication ensure smooth operation.

### CUSTOM PRODUCT CONCEPTS AND MAINTENANCE-FREE SOLUTIONS

According to the high standards of various industries, UWT's team provides extensive support for individual requirements. Customer-oriented planning enables the development of tailored solutions that are efficiently and successfully implemented.

Thanks to in-house production and a modern machine park, customised solutions and specific device adaptations can be realised.

UWT sensors are completely maintenance-free and operate on the "install and forget" principle. They are highly configurable and add value to applications.

### TOP QUALITY MEANS LONG LIFESPAN

UWT offers guaranteed "Made in Germany" quality. The high reliability of the products ensures high system availability without downtime. Continuous improvement processes and extensive testing guarantee a high level of safety. Long-lasting, maintenance-free products with a 6-year guarantee also save time and resources.

### QUALITY CERTIFICATES



### GLOBAL APPROVALS





## **SYNTHETICS INDUSTRY**

The synthetics industry is at the heart of a fascinating interplay between innovation and challenge. In a world driven by the constant pursuit of efficiency, sustainability, and technological advancement, plastics play a crucial role. From packaging to high-tech applications, plastics permeate nearly every aspect of our daily lives, providing a wide range of solutions to complex problems.

## **CHALLENGES**

Despite their versatility, plastics today face various hurdles, ranging from environmental concerns to regulatory requirements. The need to reduce the ecological footprint and develop more sustainable alternatives has pushed the industry to explore innovative solutions.

Simultaneously, issues of recyclability and waste management have come to the forefront, as the global community strives to improve the lifecycle of synthetics and minimise their negative environmental impact.

## **MATERIALS USED**

A wide variety of materials are used in the synthetics industry, ranging from traditional petrochemicals to bio-based and recycled raw materials. Polyethylene, polypropylene, polyvinyl chloride, and polystyrene are among the most widely used synthetics for a diverse range of applications.

In addition, bio-based plastics, made from renewable resources, are gaining prominence as they present a promising alternative to traditional synthetics.

## **LEVEL MEASUREMENT IN THE SYNTHETICS INDUSTRY**

In synthetics manufacturing and processing, precise level measurement helps ensure product quality, minimise production downtime, and enhance process efficiency.

In the synthetics industry, level measurement devices can be used in storage containers for raw materials such as granules or liquids like plastic melt. They allow operators to monitor current stock levels, plan replenishment in time, and avoid shortages. Additionally, level measurement devices are employed in process plants to ensure the correct quantity of material is present in processing or mixing stages, thus maintaining consistent product quality.

Given the variety of materials, different areas of application, and specific requirements in the synthetics industry, choosing the right level measurement technology is crucial.

# LEVEL AND POINT LEVEL MEASUREMENT IN STORAGE SILOS

Plastics are often stored and transported in the form of granules or powders. Storage silos enable efficient handling and storage of these materials before they are fed into the production process. Continuous monitoring of the fill level ensures that level sensors can prevent overfilling or downtime.

## CHALLENGE:

- Reliable prevention of overfilling or downtime
- Efficient material management
- Various process connections
- Complex wiring paths
- Tall, narrow silos
- High mechanical loads
- Low dielectric constant (DK) of the material

## SOLUTION:

- Absolute reliability through advanced safety features
- Level visualisation as a complete solution is possible
- Wide range of process connections
- Simple and intuitive installation/adjustment (Plug & Play)
- Sturdily and durably constructed measurement technology
- Reliable and precise level measurement of plastic granules even under challenging environmental conditions

## OUR PRODUCT RECOMMENDATION:

- RN**  
Rotonivo®
- NR**  
NivoRadar®
- NB**  
NivoBob®

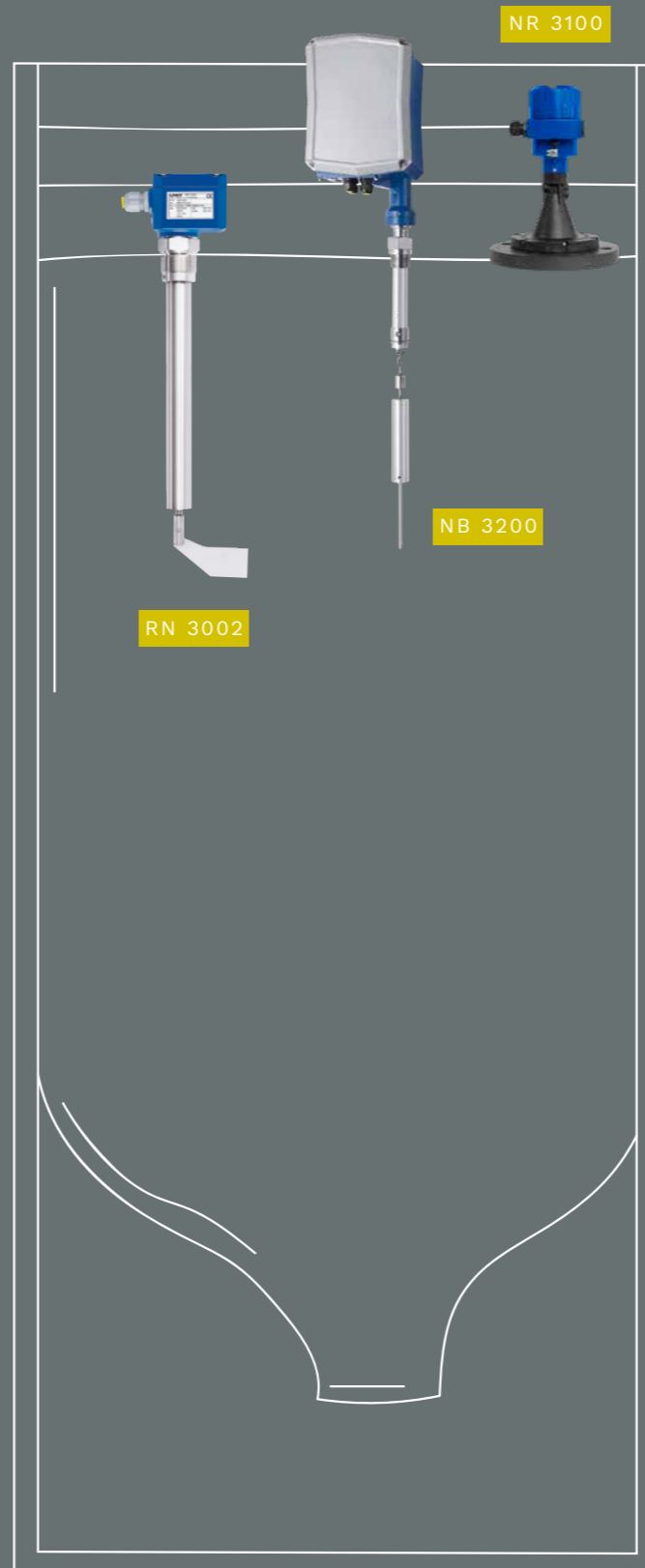

Measurement Task  
**CONTINUOUS &  
POINT LEVEL MEASUREMENT**

Medium  
**PLASTIC GRANULES**

Measuring Range  
**< 25 M | 82 FT**

Process Temperature  
**< 80 °C | 176 °F**

Process Pressure  
**< 0.8 BAR | 11.6 PSI**

STORAGE SILOS

# LEVEL AND POINT LEVEL MEASUREMENT IN TEXTILE SILOS

Raw materials are often stored in textile silos. Full and empty detectors are sewn into the textile silos using a flange and take over level control. Radar sensors can penetrate the textile fabric and continuously monitor the fill level.

## CHALLENGE:

- No defined process connections
- Short measuring distances
- No reflection from the container bottom
- Challenging installation conditions

## SOLUTION:

- Wide range of process connections
- Level sensors for short measuring distances
- Precise measurement results
- Level measurement through the container roof
- Interference signal suppression in the presence of struts
- Sensors in lightweight design

## OUR PRODUCT RECOMMENDATION:

**NR**  
**NivoRadar®**

**RN**  
**Rotonivo®**

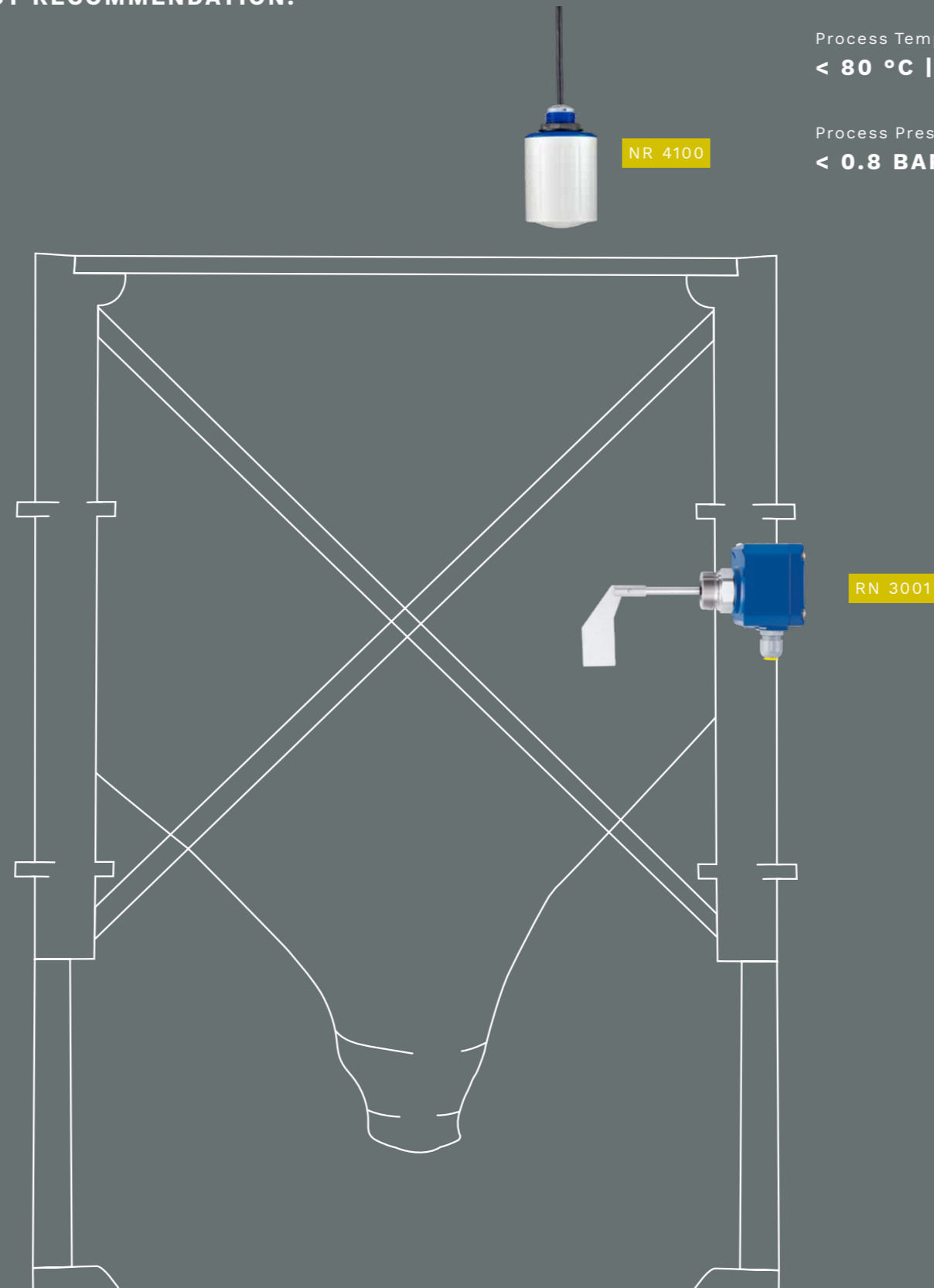

Measurement Task  
**CONTINUOUS &  
POINT LEVEL MEASUREMENT**

Medium  
**PLASTIC GRANULES**

Measuring Range  
**< 3 M | 9.84 FT**

Process Temperature  
**< 80 °C | 176 °F**

Process Pressure  
**< 0.8 BAR | 11.6 PSI**

S  
O  
T  
I  
S  
E  
T  
T  
I  
N  
G  
T  
E  
X  
T  
I  
L  
E  
S  
I  
L  
O  
S

# POINT LEVEL MEASUREMENT IN DRYING SYSTEMS & INTERMEDIATE CONTAINERS

The drying of plastic granules is a crucial step in further processing to remove moisture and ensure the quality of the final product. At this stage, mixing with dyes, stabilisers, or other additives can also take place. Level sensors continuously monitor the contents of the respective containers

## OUR PRODUCT RECOMMENDATION:

- RN**  
**Rotonivo®**
- CN**  
**Capanivo®**

## CHALLENGE:

- Fluctuating process temperature and residual material moisture
- Confined installation conditions
- High process speed
- Continuous material flow
- Varying bulk densities

## SOLUTION:

- Resistant to temperature and moisture fluctuations
- Compact design
- Rapid reprogramming during material changes via IO-Link
- Fast response time
- Adjustable sensitivity

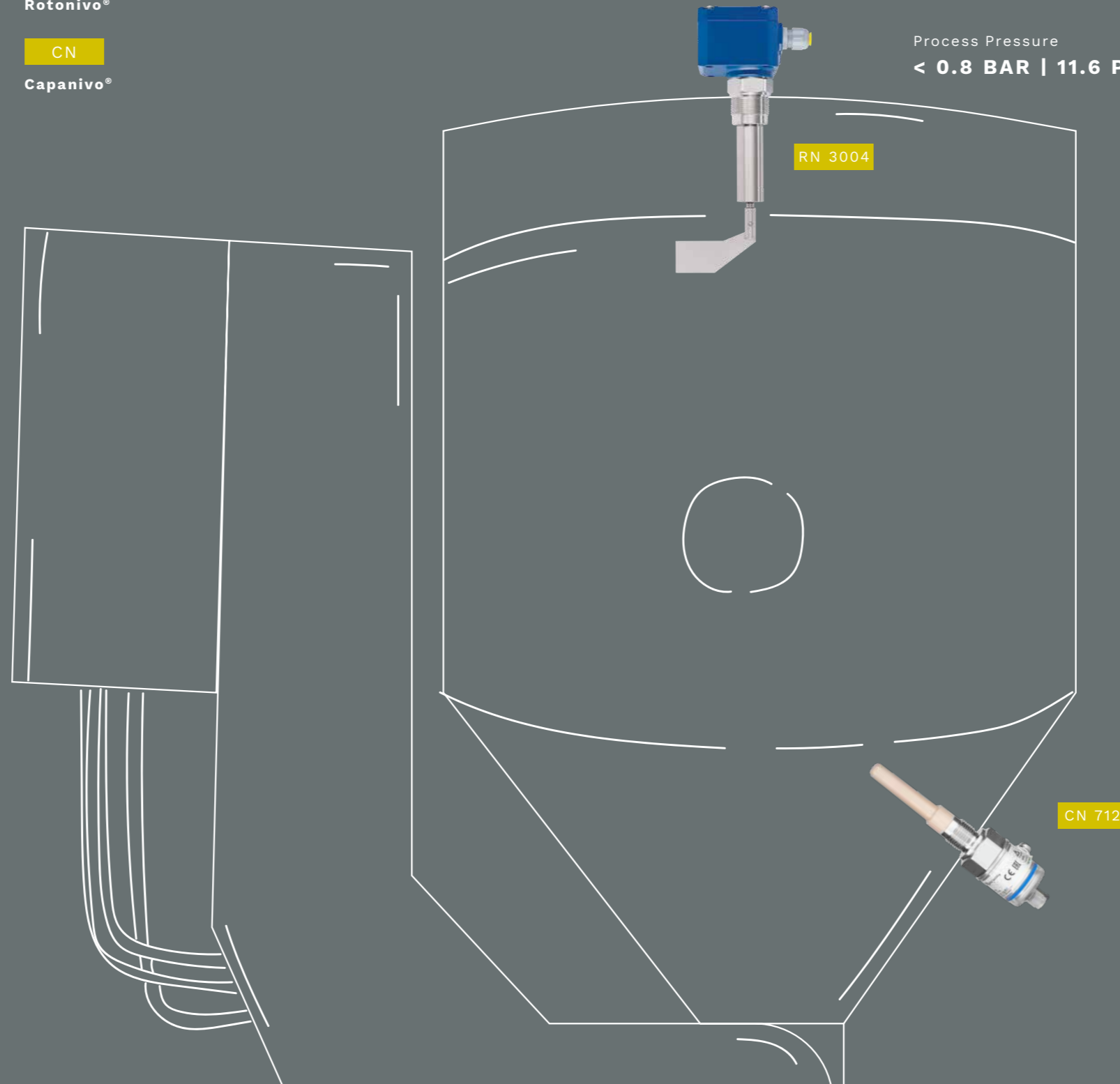

Measurement Task  
**POINT LEVEL MEASUREMENT**

Medium  
**PLASTIC GRANULES,  
PLASTIC PELLETS**

Measuring Range  
**< 1 M | 3.28 FT**

Process Temperature  
**< 120 °C | 280 °F**

Process Pressure  
**< 0.8 BAR | 11.6 PSI**

DRYING SYSTEMS  
& INTERMEDIATE  
CONTAINERS

# POINT LEVEL MEASUREMENT IN DOSING AND MIXING CONTAINERS

In an extrusion plant, dosing and mixing containers are often used to precisely measure and mix raw materials before they enter the extruder. The dosing container ensures that the exact amount of raw materials, such as powder or granules, is measured for the extrusion process.

## OUR PRODUCT RECOMMENDATION:

- CN  
Capanivo®
- RN  
Rotonivo®

## CHALLENGE:

- High ambient temperature
- Rapid material flow
- Confined installation conditions

## SOLUTION:

- Temperature-resistant at ambient temperatures up to 80 °C (176 °F)
- Reliable and fast point level detection
- Durable measurement technology
- Compact design

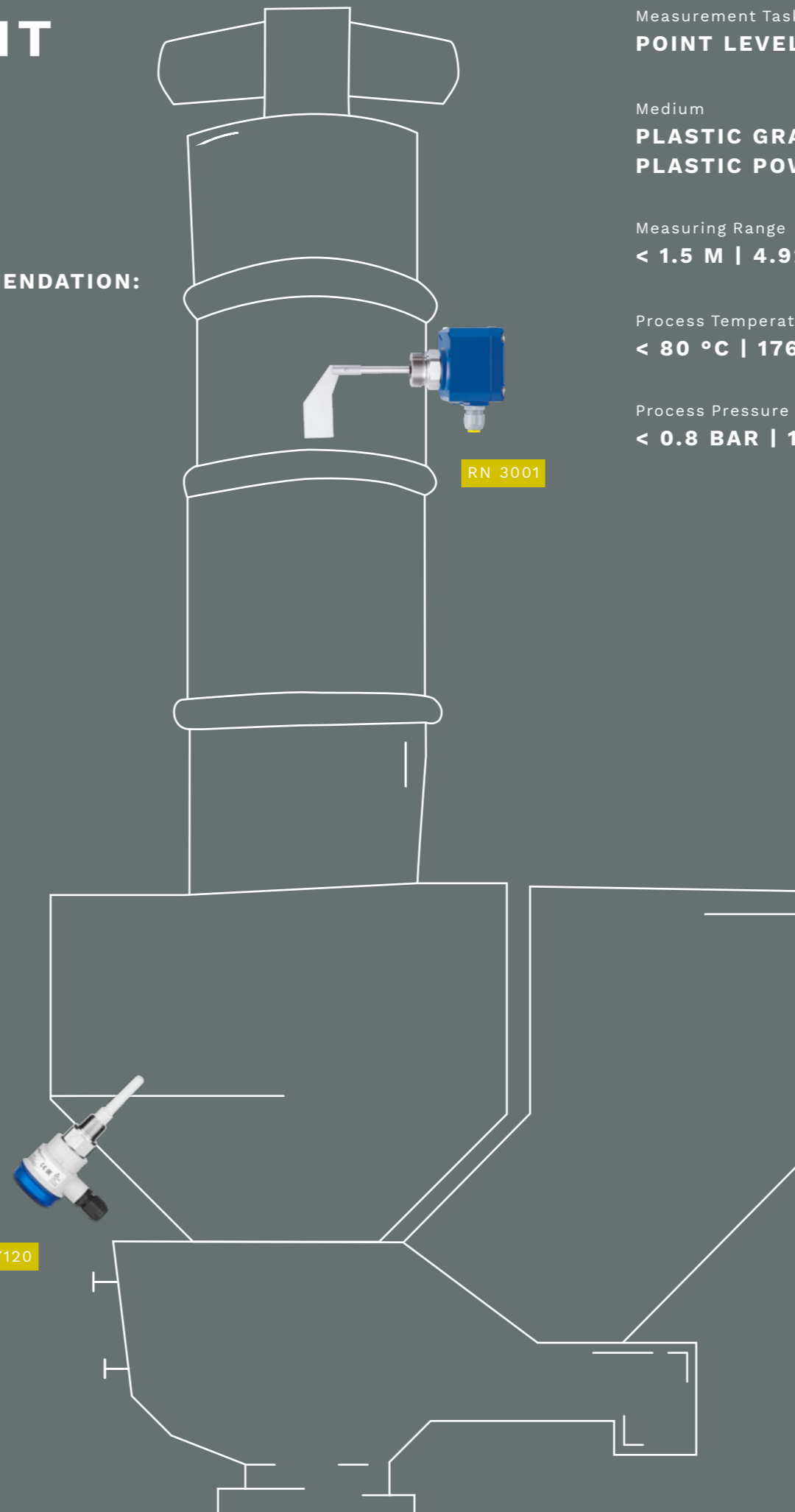

Measurement Task  
**POINT LEVEL MEASUREMENT**

Medium  
**PLASTIC GRANULES,  
PLASTIC POWDER**

Measuring Range  
**< 1.5 M | 4.92 FT**

Process Temperature  
**< 80 °C | 176 °F**

Process Pressure  
**< 0.8 BAR | 11.6 PSI**

DOSING & MIXING  
CONTAINERS

# POINT LEVEL MEASUREMENT DURING GRINDING AND CRUSHING PROCESSES

The grinding of plastic granules is a process in which the granules are crushed into smaller particles or powder. After processing, the plastics are collected in buffer containers. Point level sensors monitor the fill level during this process.

## OUR PRODUCT RECOMMENDATION:

- RN**  
**Rotonivo®**
- MN**  
**Mononivo®**

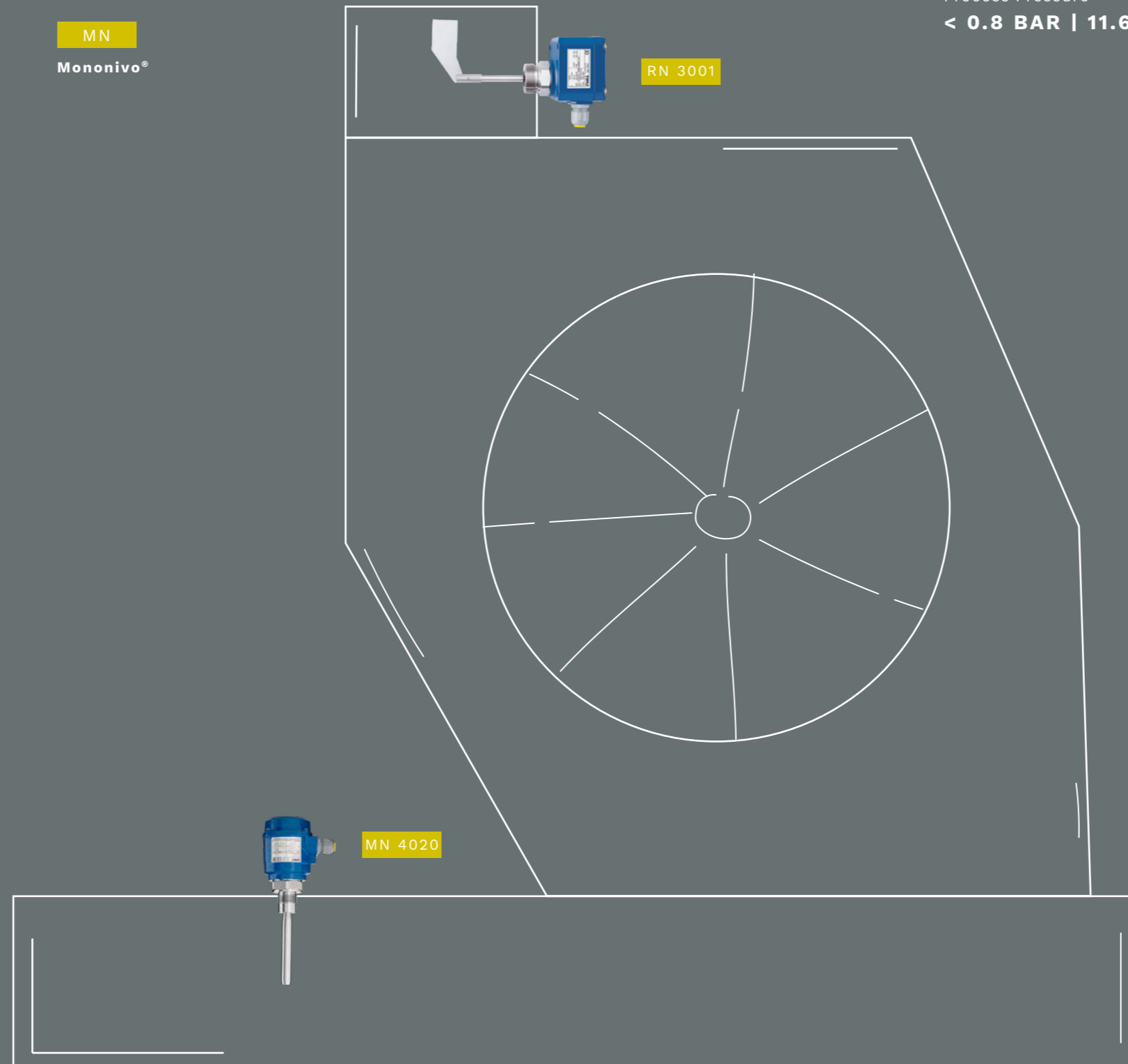

Measurement Task  
**POINT LEVEL MEASUREMENT**

Medium  
**PLASTIC GRANULES**

Measuring Range  
**< 1 M | 3.28 FT**

Process Temperature  
**< 80 °C | 176 °F**

Process Pressure  
**< 0.8 BAR | 11.6 PSI**

## CHALLENGE:

- Material backlog
- Confined installation conditions
- Continuous material flow
- Harsh process conditions
- Varying material particle size

## SOLUTION:

- Reliable and fast point level detection
- Compact design
- Durable measurement technology
- Measurement independent of material particle size

GRINDING  
CRUSHING  
PROCESS

# POINT LEVEL MEASUREMENT IN THE FEED HOPPER - FEEDING INTO THE EXTRUSION MACHINE

The prepared plastic granules are poured into the hoppers or feed devices of the extrusion machine. Point level sensors monitor the continuous material supply, enabling an uninterrupted production process. The extrusion machine then melts the granules and forms them into a continuous mass, known as the extrudate.

## OUR PRODUCT RECOMMENDATION:

**RN**  
**Rotonivo®**

## CHALLENGE:

- Elevated process temperature
- Build-up and residue formation
- Process-critical measuring point
- Continuous material flow

## SOLUTION:

- Temperature-resistant up to 250 °C / 482 °F
- Reliable and fast point level detection
- Sturdily and durably constructed measurement technology

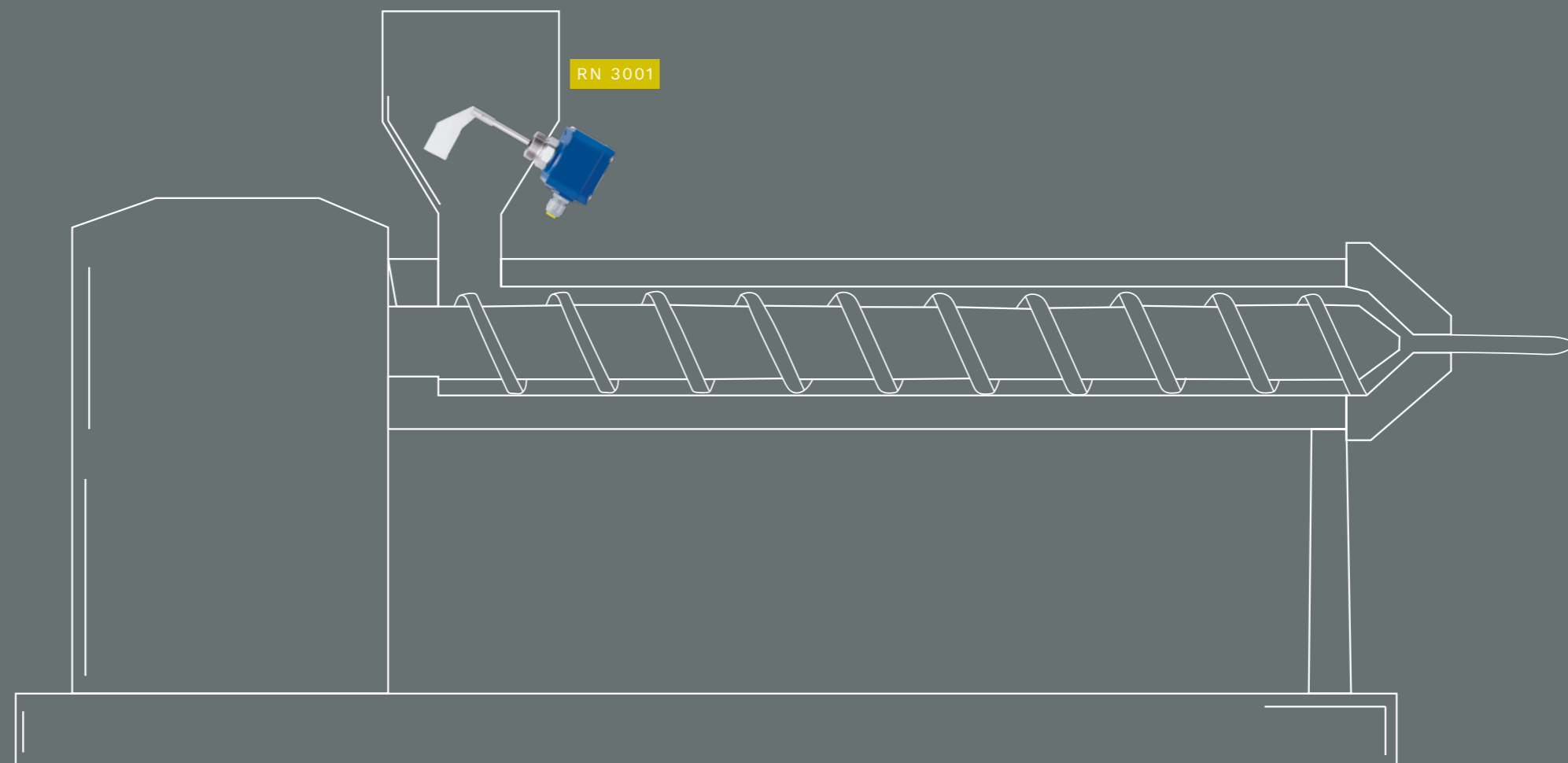

Measurement Task  
**POINT LEVEL MEASUREMENT**

Medium  
**VARIOUS PLASTICS**

Measuring Range  
**< 1 M | 3.28 FT**

Process Temperature  
**< 250 °C | 176 °F**

Process Pressure  
**< 0.8 BAR | 11.6 PSI**

EXTRUSION  
MACHINE

# BACKFLOW DETECTION IN REGRANULATION

Waste or defective products are regranulated in a resource-efficient manner. The finished plastic components are crushed and transported via conveyor belts to the subsequent production steps. Collection containers are often used for sorting, interim storage, or material control. Point level sensors prevent overfilling of the containers and ensure a continuous material flow.

## CHALLENGE:

- Sharp-edged plastic flakes
- Contaminated and wet bulk materials
- Harsh process conditions
- Continuous material flow
- Varying material particle size

## SOLUTION:

- Robust and durable design
- Resistant to moisture
- Measurement independent of material particle size

## OUR PRODUCT RECOMMENDATION:

MN  
Mononivo®

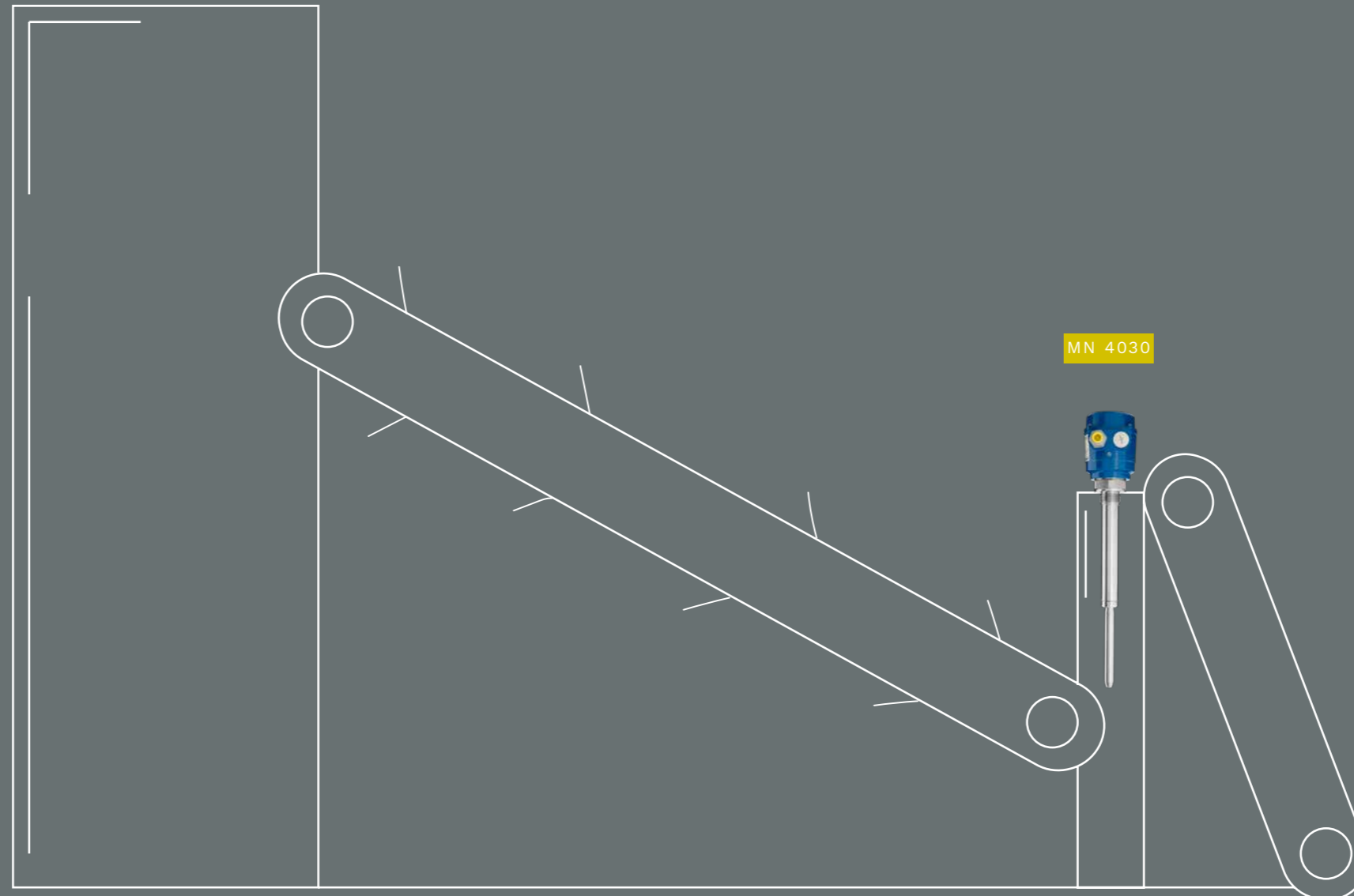

Measurement Task  
**POINT LEVEL MEASUREMENT**

Medium  
**PLASTIC FLAKES**

Measuring Range  
**< 1 M | 3.28 FT**

Process Temperature  
**< 80 °C | 176 °F**

Process Pressure  
**< 0.8 BAR | 11.6 PSI**

REGRANULATION

# POINT LEVEL MEASUREMENT DURING THE CONVEYING OF COOLED AND HARDENED END PRODUCTS

After the molten plastic granules have been shaped into the desired form, they are cooled to harden and achieve their final structure. This step is particularly important to ensure the shape stability of the end product. The finished end product is then stored in containers and prepared for packaging. Point level sensors monitor the contents of the containers gently to avoid damage to the material.

## CHALLENGE:

- Variably sized plastic parts
- High residual temperature
- Sensitive end products

## SOLUTION:

- Non-contact level measurement
- High sensitivity
- Temperature-resistant at process temperatures up to 150 °C (302 °F)
- Product-friendly technology

## OUR PRODUCT RECOMMENDATION:

MN  
Mononivo®

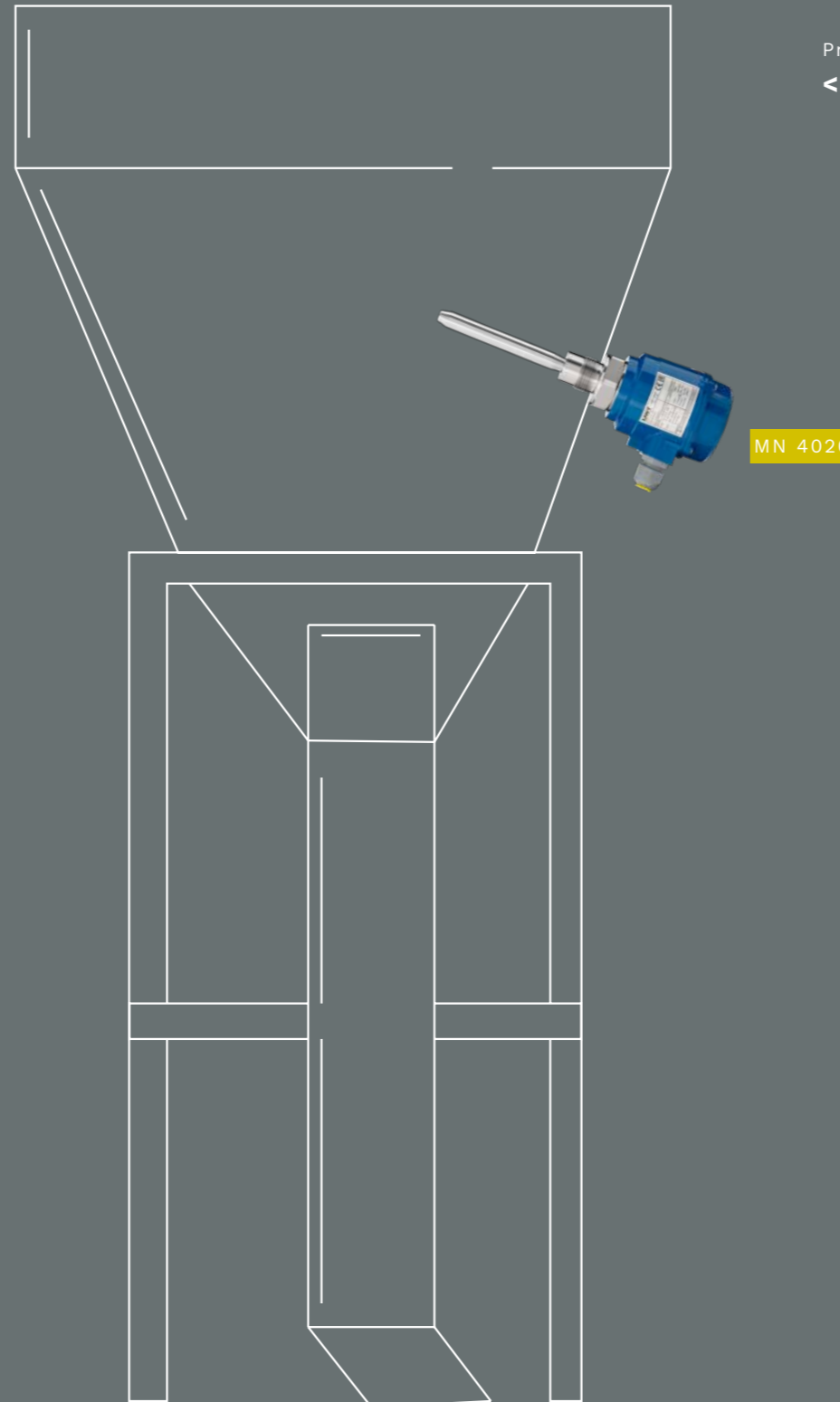

Measurement Task  
**POINT LEVEL MEASUREMENT**

Medium  
**END PRODUCTS  
MADE OF PLASTIC**

Measuring Range  
**< 2 M | 6.56 FT**

Process Temperature  
**< 80 °C | 176 °F**

Process Pressure  
**< 0.8 BAR | 11.6 PSI**

END PRODUCTS

# LEVEL VISUALISATION WITH THE APPROPRIATE MEASUREMENT TECHNOLOGY

An internationally active plastic processor faced the challenge of capturing the exact fill levels of the silo batteries at three production sites in real-time and making this information centrally accessible.

Furthermore, the sensors had to operate reliably and precisely, regardless of the varying properties of the stored plastic granules, such as the dielectric constant (DK), dust generation, or fluctuating temperatures.

## OUR SOLUTION

Our customised UWT solution for this application was implemented through a combined installation of the NivoTec® 3500 for level monitoring, the electromechanical float system NivoBob® 3100 for level measurement, and the full detector RN 3002 from the Rotonivo® series.



## CORE COMPONENTS OF THIS CUSTOM SYSTEM SOLUTION

The central monitoring of fill levels across multiple silo batteries at various locations imposes specific requirements on the communication and measurement systems:

### Precision and Reliability:

The NivoBob® 3100 level sensors provide accurate measurement data that is independent of the varying properties of the plastic granules. This reliability is crucial for obtaining consistent and usable information. To prevent silo overfilling, the full detector RN 3002 from the Rotonivo® series is employed. This sensor continuously monitors the maximum fill level and issues timely alarms to prevent overflow.

### Real-Time Data Availability:

For efficient production planning, it is essential that the fill levels are available in real time. Communication between the level sensors and the central visualisation occurs via a Modbus network. This protocol ensures that the measurement data is transmitted immediately and without delay.

### Central Management:

The visualisation system NivoTec® - NT 3500 provides a comprehensive display, allowing the fill levels of all locations to be centrally managed and monitored. Three silo systems have been connected to the NT 3500 controller via gateways and VPN tunnels, ensuring secure and reliable data transmission. This enables management to respond quickly to changes and make informed decisions.

## BENEFITS AND RESULTS

This project implementation by UWT offers the plastic processor numerous advantages

### Efficiency Improvement:

By centralising the capture and real-time display of fill levels, production processes can be better planned and resources optimally utilised.

### Cost Savings:

The precise level measurement and prevention of overfilling reduce material losses and production downtime.

### Increased Operational Safety:

The use of reliable sensors and a robust communication network minimises the risk of measurement errors and technical failures.



Application reports



Application Database

# LEVEL MONITORING AND VISUALISATION DISPLAY

## NivoTec®

Various technologies are available for level display. Simple LED digital displays for evaluating a 4-20 mA signal can be integrated into control cabinets or wall-mounted, ranging up to touch panels and web server modules with visualisation software. These can be configured on a project basis and customised to meet customer requirements.

UWT offers standardised products from the NivoTec® NT 4000 series, which meet many requirements for level display and monitoring at a competitive price. The NivoTec® NT 3000 series can be customised for individual customer projects. This web server solution meets all the requirements of modern level monitoring.



NivoTec®  
Level monitoring and visualisation



**NivoTec® NT 4600**  
7 inch touch panel visualisation



**NivoTec® NT 4700**  
Digital Display in terminal box for one measuring point



**NivoTec® NT 4900**  
Digital display as built-in module



**NivoTec® NT 9000**  
Local fill level display



**NivoTec® NT 3500**  
Custom project visualisation



**NivoTec® NT 4500**  
Standardised visualisation

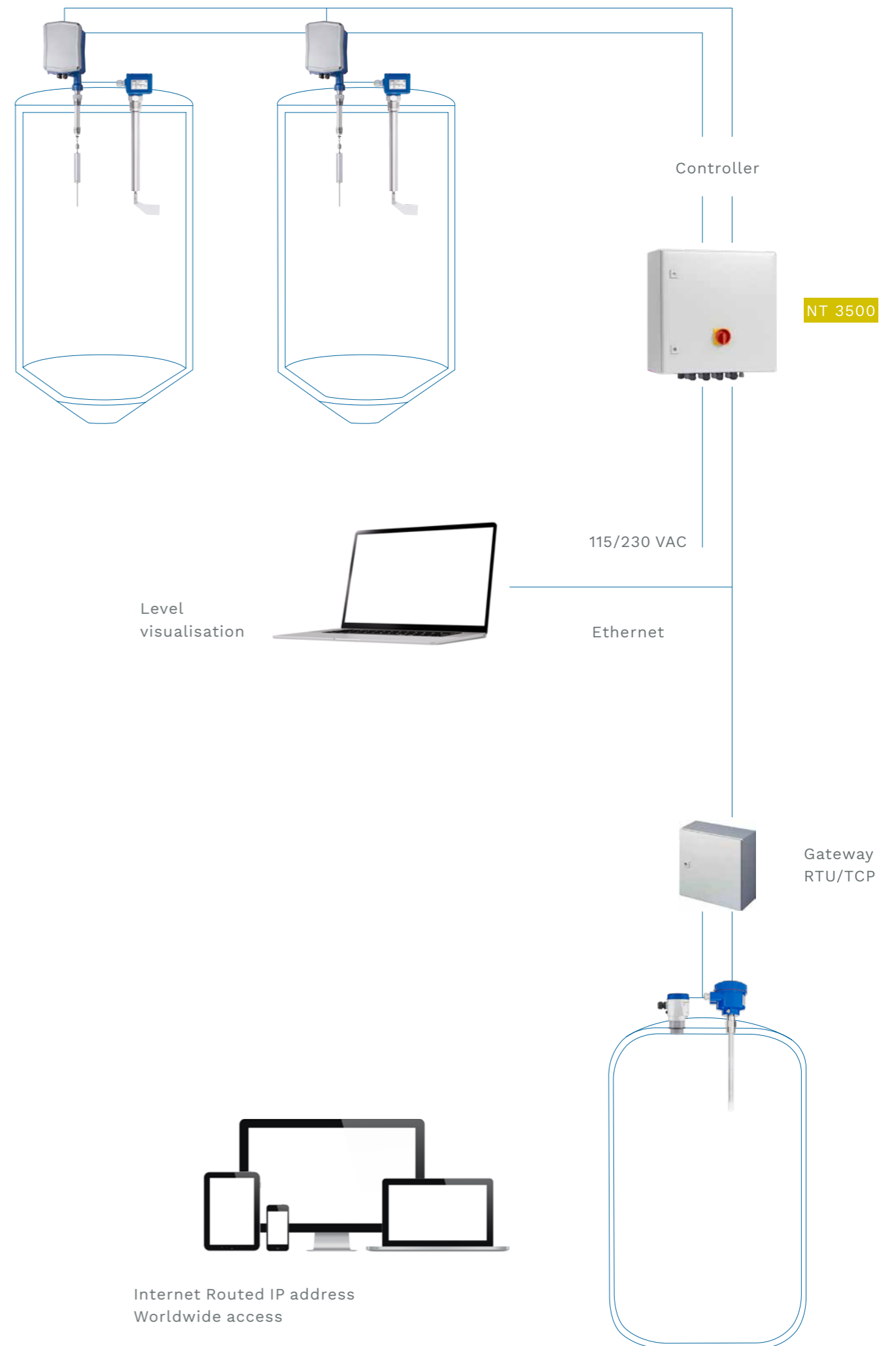

# UWT

LEVEL. UP TO THE MAX.

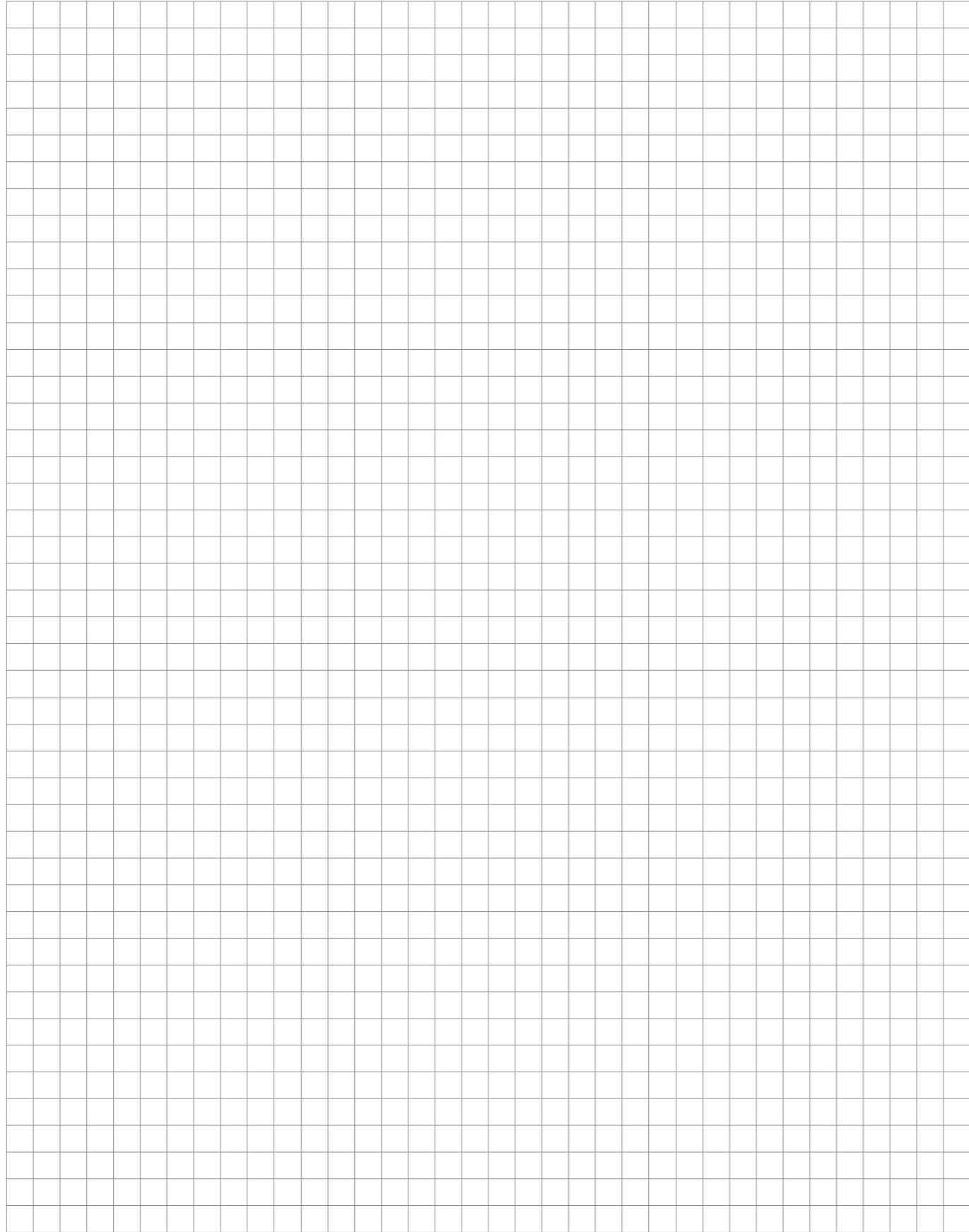

# UWT

LEVEL. UP TO THE MAX.

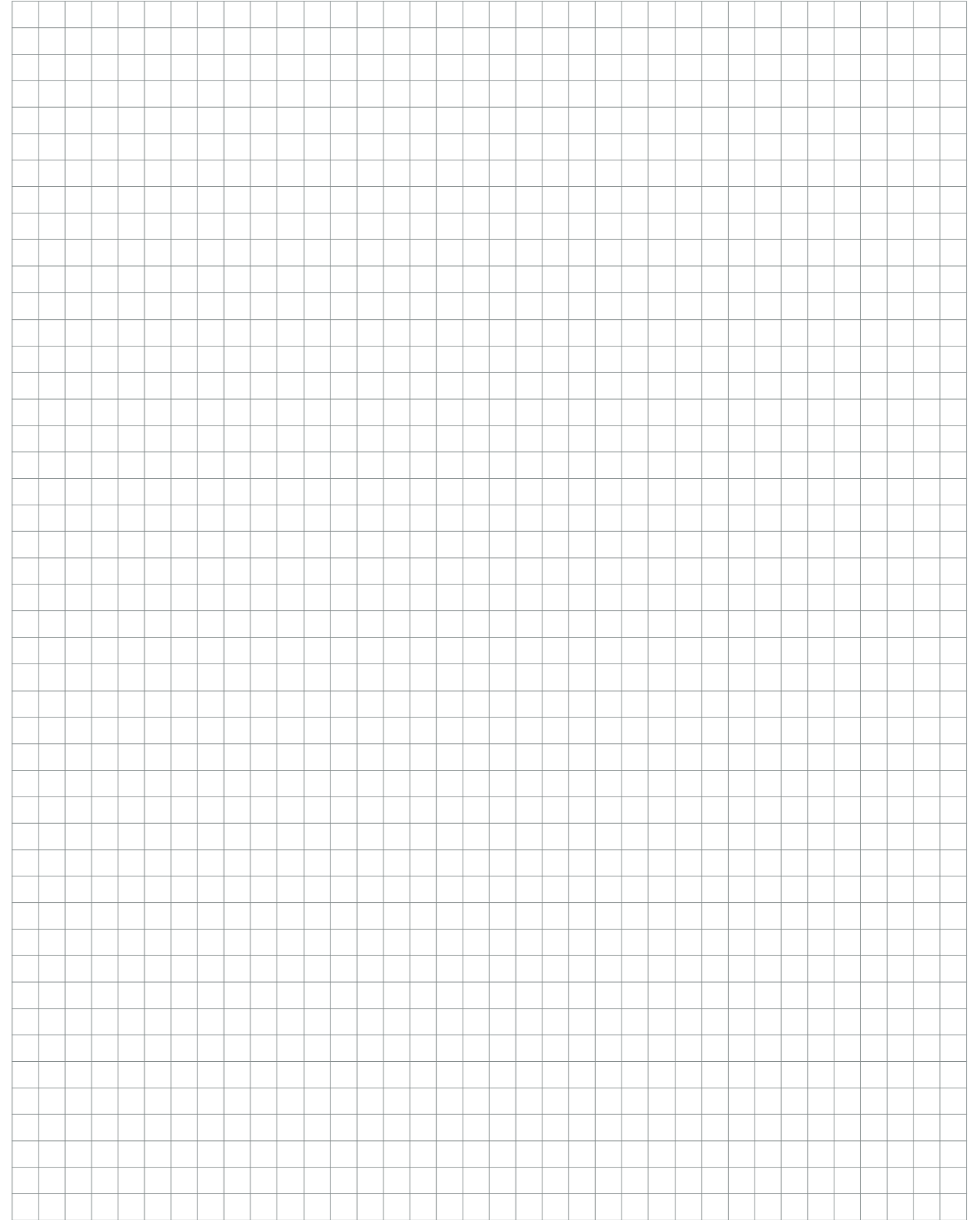

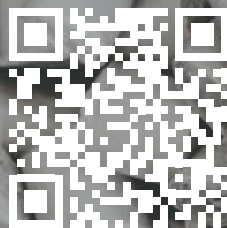

[uwtgroup.com/en/productoverview](https://www.uwtgroup.com/en/productoverview)

Westendstr. 5 | 87488 Betzigau | Germany  
Tel +49 831 57123-0 | [info@uwtgroup.com](mailto:info@uwtgroup.com)